

# Radio Broadcast

ROY MASON, EDITOR



## CONTENTS FOR JUNE, 1922

<i>Dr. Lee De Forest</i> - - - - -	<i>Frontispiece</i>
THE MARCH OF RADIO - - - - -	95
OBJECTS THAT DISTORT RADIO WAVES - - - - -	L. E. WHITTEMORE 101
TUNING THE RADIO AERIAL SYSTEM - - - - -	JOHN V. L. HOGAN 107
WHAT RECEIVING SET SHALL I BUY? - - - - -	J. CONRAD FLEMMING 110
BROADCASTING ON POWER LINES - - - - -	115
WIRE BROADCASTING - - - - -	JOHN F. DUNCAN 116
CARE AND OPERATION OF A CRYSTAL RECEIVING SET	EDGAR H. FELIX 120
KEEPING THE STARS AND STRIPES IN THE ETHER	COMMANDER STANFORD C. HOOPER, U. S. N. 125
RADIO PERSONALITIES - - - - -	132
R. A. HEISING - - - - -	EDGAR H. FELIX
PROMINENT RADIO EDITORS - - - - -	135
WHAT THE DETROIT "NEWS" HAS DONE IN BROADCASTING	R. J. McLAUCHLIN 136
THE AMATEUR RADIO LABORATORY - - - - -	ZEH BOUCK 142
MISTAKES TO AVOID IN ERECTING ANTENNAS - - - - -	G. Y. ALLEN 145
HOW TO BEGIN TO ENJOY RADIO - - -	CAPTAIN LEON H. RICHMOND, U. S. A. 151
THE PACIFIC COAST IS "ON THE AIR" - - - - -	WILBUR HALL 157
ADVENTURES IN RADIO - - - - -	PIERRE BOUCHERON 162
Married by Radio	
Sunk by Radio	
MAKING RADIO SALES PAY - - - - -	ARTHUR H. LYNCH 166
THE GRID—QUESTIONS AND ANSWERS - - - - -	178
NEW EQUIPMENT - - - - -	180

Copyright, 1922, by Doubleday, Page & Co. All rights reserved  
TERMS: \$3.00 a year; single copies 25 cents

F. N. DOUBLEDAY, Pres.  
RUSSELL DOUBLEDAY, Sec'y.

ARTHUR W. PAGE, Vice-Pres.  
S. A. EVERITT, Treas.

NELSON DOUBLEDAY, Vice-Pres.  
JOHN J. HESSIAN, Asst. Treas.

### DOUBLEDAY, PAGE & CO.

THE WORLD'S WORK    COUNTRY LIFE    THE GARDEN MAGAZINE    SHORT STORIES    EDUCATIONAL REVIEW

CHICAGO: People's Gas Bldg.

GARDEN CITY, N. Y.

NEW YORK: 120 W. 32nd Street

BOSTON: Tremont Bldg.

LOS ANGELES: Van Nuys Bldg.

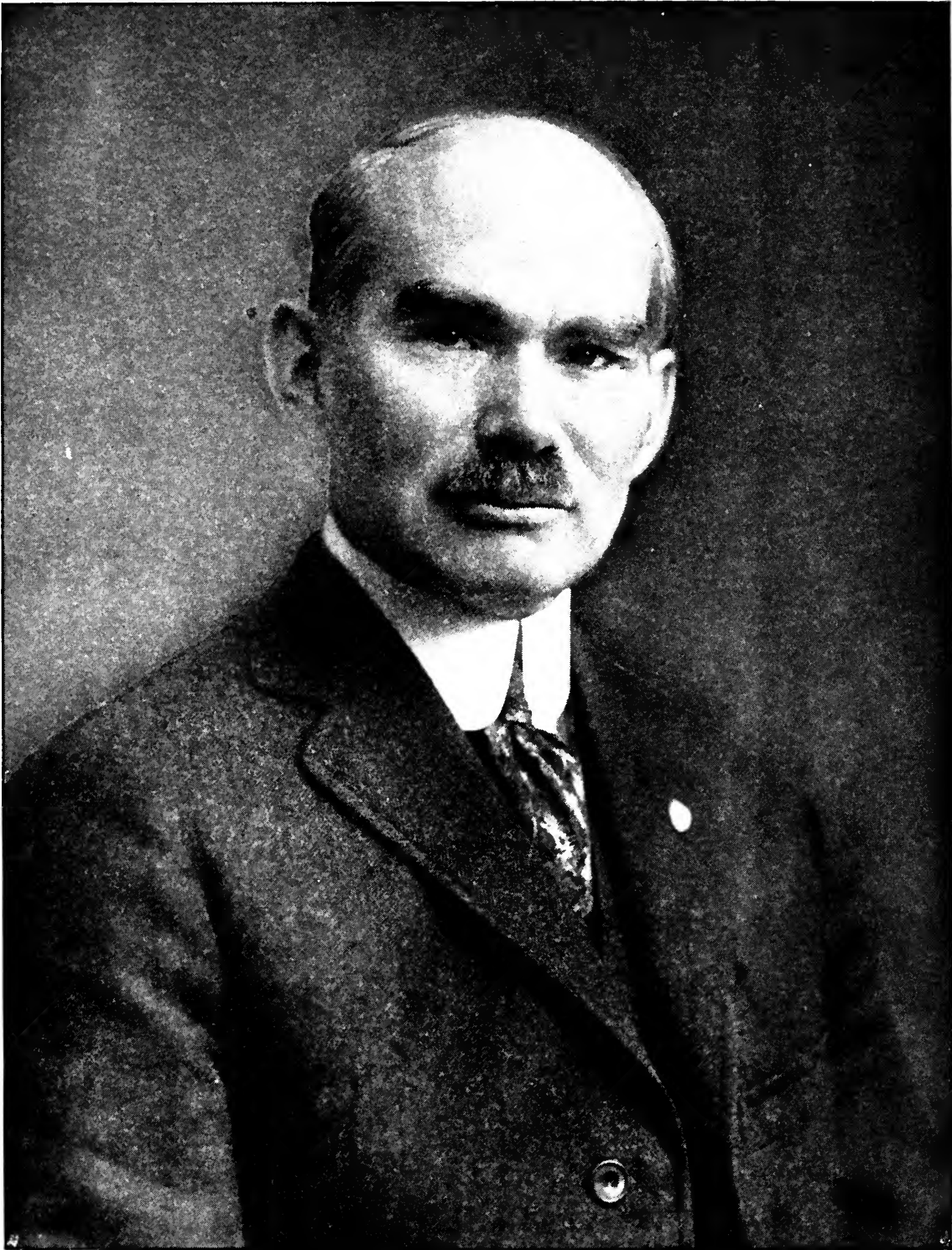

DR. LEE DE FOREST  
Inventor of the Vacuum Tube

# RADIO BROADCAST

Vol. 1 No. 2



June, 1922

## The March of Radio

**T**HE rush of radio news in the daily press is an amazing mixture of quaint and fanciful ideas, new developments and applications, and serious articles on stirring events that may well be milestones in the progress of civilization.

In the first category falls the story of a foreign hypnotist, who undertook to put three subjects to sleep by radiophone, all the way from John Wanamaker's store up to the Hotel Astor, New York, a distance of more than two miles. The papers are discreetly silent as to the result.

Then there was a fanciful story of an inventor who committed suicide by turning on the gas in New York City as he listened by radiophone to a dirge being played for a funeral on a ship far out at sea. Just how the reporter ascertained what were the last sounds heard by the dying inventor's ears is left to the reader's imagination.

Evidence that the radio business has assumed a stable place among our business institutions is afforded by the facts that classified advertisements for radio salesmen and radio engineers are now appearing in the newspapers, that radiophone receiving sets are appearing in pawnshop windows, a sure guarantee that there is an active market for them, and that down town on Fulton Street, west of Greenwich Street in New York, office boys now congregate daily to exchange the parts of radio apparatus they don't want for others that they do.

But the best evidence of the rapidly growing

importance of this business was the announcement of the calling of the first Radio Conference of Retail Merchants at the Hotel Pennsylvania on April 18. According to a preliminary report of the Bureau of Research and Information of the National Retail Dry Goods Association, the volume of radio business will reach \$70,000,000 this year.

Some of the novel applications of the radiophone, according to the newspapers, have been the supplying of a long vacant pulpit in Wheeling, W. Va., by means of a receiving set, the installation of sets with amplifiers in hotels and apartment houses, the use of radio to broadcast the news of a concert recital and dance under the auspices of the National Child Labor Committee, and the broadcasting of a concert and the preaching of a "sermon from the clouds" by Lieut. W. B. Maynard, known as the "flying parson," from his airplane over New York City. Lieut. Maynard also officiated at a radio aerial wedding on April 24, three thousand feet above Times Square, in New York City. The principals were Miss Sarah Cockefair and Albert P. Schlafke.

So great is the interest and enthusiasm of radio amateurs that many of them misinterpreted the newspaper accounts of General Squier's discovery, and endeavored to substitute the electric light circuits in their homes for antennas, with more or less disastrous results to both the circuits and their radio outfits.

One of the more serious news items is to the effect that Major-General Robert Lee Bullard, in charge of the operations of the citizens'

military training camps, sent out a stirring call for recruits from the United States Army Broadcasting station at Bedloe's Island, where the statue of Liberty stands. The possibilities of instant mobilization, in case of future wars, which this suggests, stagger the imagination.

The exploits of David W. Richardson and G. D. Murray, the two Princeton students who succeeded in sending and receiving radio messages from a Lackawanna railroad train while it was roaring through ravines and cuts at the rate of 65 miles an hour, and even passing



© Underwood & Underwood

Lackawanna Railroad coach specially fitted with aerial for radio tests

through long tunnels, have filled many columns in the press. Over in France the Compagnie du Nord has been making similar experiments under the direction of the French Ministry of Public Works near Bourget-Triage, but not while the train was running at great speed, nor over long distances.

Another important news item, if true, is to the effect that patrol automobiles of the New York Police Department are to be equipped with radiophone apparatus for the reception and transmission of wireless messages from and to Police Headquarters. The possibilities this suggests of throwing radio nets around automobile bandits and even speeders are interesting.

At this time when constant attempts are being made to fly across the ocean, it is good news that naval experts have perfected a method of keeping track of airplanes on overseas flights. Hereafter transoceanic planes are to fly in pairs, the leader to report their position every half hour, and in case of accident to either, the one in the air to report the circumstances, as the one on the water would be too low for satisfactory radio communication.

The Navy Radio Bill, which extends to June 30, 1925, the time during which Government owned radio will be allowed to handle press and commercial messages, except those

to China, has been adopted by the House and Senate and signed by President Harding. The service to Chinese stations will be terminated January 1, 1924, owing to international wireless agreements.

The Weather Bureau is promising more radio weather news, giving advance information of good and bad weather, and the Post Office Department is equipping its transcontinental and other airplanes with radiophone outfits with a radius of 200 miles.

The London *Daily Mail* accuses the "old fogies" of the army and navy air forces of hampering English amateurs. It is said that the United Kingdom has only 8,000 amateurs.

Captain Roald Amundsen, the explorer, who has started for the Arctic, is taking along radio outfits, not only for his ship, the *Maud*, but for two powerful airplanes which will form part of his equipment. As Captain Amundsen is said to estimate the duration of his voyage at from three to five years, it is safe to say that his radio equipment will be obsolete by the time he returns. In the meantime he and his crew will be able to find out the name of our next President, and we shall know if the brave Captain gets into any trouble and needs help.

Senator Harry S. New of Indiana made a political speech by navy radio to a meeting of women voters in Indianapolis and all other voters in Indiana who had receiving sets able to tune into the navy wave length, and thereby stirred up a tempest in a teapot. Once more the familiar cry is heard of using Government

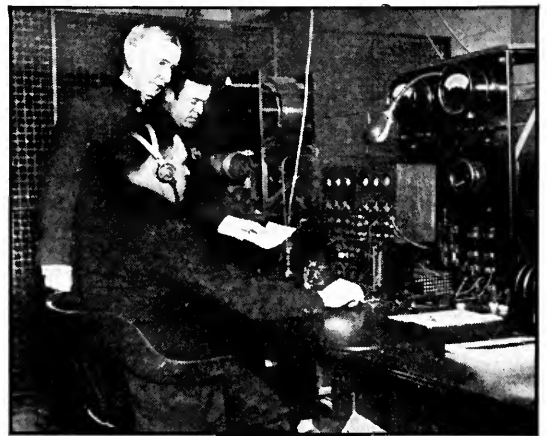

© Kadel & Herbert

New York's Police Department Radio System. This installation has been of great use in calling out the reserves, when needed, and relaying messages to the police boats in the running down of bootleggers smuggling liquor. It will shortly serve to keep Police Headquarters in touch with the Department's patrol automobiles





© Harris &amp; Ewing

Senator Harry S. New of Indiana, to whom the distinction of making the first political speech by radio belongs

instrumentalities for political ends. It is safe to predict that men of all political parties will be accorded equal privileges, or that none at all will have them.

The American Telephone and Telegraph Company has disposed of its interest in the Radio Corporation of America.

Dr. Lee De Forest is reported to have invented a method of registering the action and voices of a photoplay in the same film.

Nearly two hundred daily newspapers in the United States are now maintaining radio news departments, and the number is constantly growing. The great majority of them are published on the Atlantic Coast. Nearly two score newspapers in New England maintain such departments, fifteen in the Southern states, and eleven enterprising newspapers on the Pacific Coast.

### R. C. A. Annual Report

**T**HE Transatlantic circuits of the Radio Corporation of America are now carrying 20 per cent. of the international message traffic between the United States and Europe, it is stated in the annual report of the corporation to the stockholders. Six direct international radio communication circuits are now in operation: Great Britain, opened March 1, 1920; Norway, opened May 17, 1920; Germany, two circuits, the first opened August 1, 1920, and the second May 19, 1921; France opened December 14, 1920; Hawaii and Japan, opened March 1, 1920.

"At the beginning of 1921," the report

states, "your corporation had in operation two Transatlantic high-power transmitting stations, one at New Brunswick, N. J., and the other at Marion, Mass. The station at Tuckerton, N. J. originally constructed by a German company, was of unsatisfactory design to meet the demands of Transatlantic service. The reconstruction of this station by the Radio Corporation of America made it ready for commercial traffic in January, 1921. The Tuckerton station now furnishes the transmitters for use on two distinct European circuits. At Radio Central, Rocky Point, L. I., construction work commenced during the previous year was completed to such a point that on November 5, 1921, the station was officially opened. When completed, this station will be a multiple station of twelve units, each consisting of a complete transmitter, and an antenna nearly one and a half miles long, supported by six steel towers, each 400 feet in height. The first unit of Radio Central was formally opened by President Harding. The message was acknowledged by 19 countries of the world, including Japan, Australia and New Zealand.

"The installation of high-power stations in South America has been inaugurated, by joint arrangement with the French, German and English companies, under which the interests of the four companies are trusteeed, with an American chairman chosen by the Radio Corporation of America. A station is now being erected in Argentine, and a concession has been

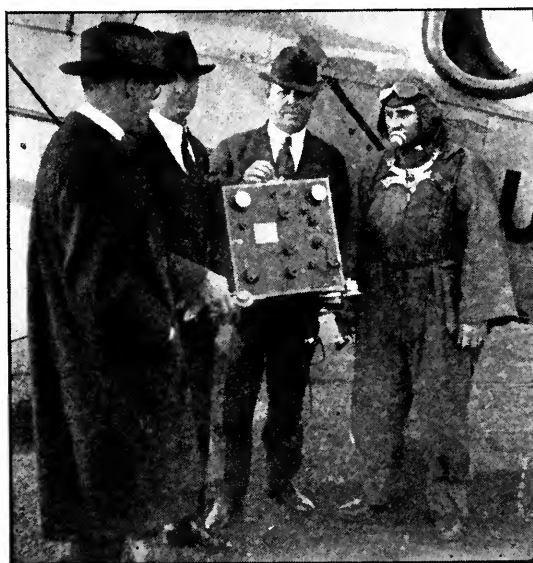

© Underwood &amp; Underwood

Air Mail Plane Radiophone

obtained and financial commitments made in Brazil. At Warsaw, Poland, the Radio Corporation of America is now erecting a high-power station. One-half of the necessary radio equipment has been forwarded to Poland from the United States, and American engineers are making the installation."

#### Vacuum Tubes Promised

EVERY effort is being made by the manufacturers to meet the great demand for vacuum tubes—the very "heart of the radio." The Radio Corporation of America announces that the May production of vacuum tubes, used in radio transmitting and receiving sets, by the companies which it represents, will reach 175,000. The production scheduled for June calls for a total delivery of 200,000.

Crystal detectors formerly served the purposes of the larger number of amateurs, but the present popularity of broadcasting has created the demand for vacuum tubes. Although machines play a part in the major processes of manufacture, tubes are still largely made by

hand. Hand work plays a far more important part in making them than in the making of any other piece of electrical apparatus with which the public is familiar.

The manufacture of the delicate vacuum tubes used as detectors, transmitters, and amplifiers requires the building up of a force of technically trained men to work in the factories. That this is being rapidly done is proved by the fact that during the first eleven months of 1921 the average production of vacuum tubes by these companies was 5,000, in December the production schedule was increased to 40,000, in January to 60,000, and the production in April was expected to reach 150,000.

#### Russia and Radio

JUST to what extent Soviet Russia is making use of radio for external and internal communication remains to be heard when the truth once comes out of that dark country. At any rate, Russia is certainly exerting every effort to secure every possible

Spanish Royalty inspects new wireless. King Alphonso and Queen Victoria Eugenie of Spain are shown at the opening of the new wireless station in Madrid which has opened communication with Bilbao

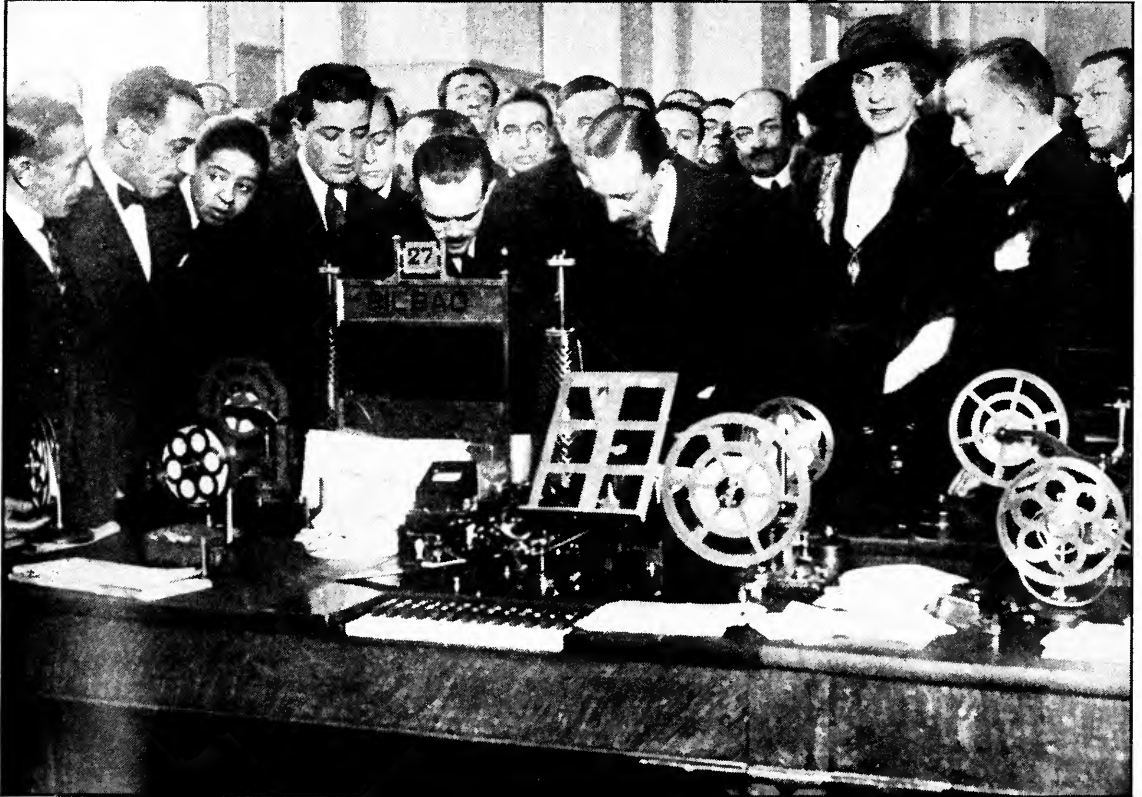

means of radio communication with the outside world. Now we learn that a radio service between Stockholm and Petrograd was inaugurated recently.

### A New Russian Station

A *Central News* message states that a powerful radio station, capable of direct communication with Germany, England, Denmark, and Norway is nearing completion at Dietskoye Selo in Russia. It has been planned entirely by Russian engineers and erected by Russian labor.

### Cable and Radio

AN interesting and convincing comparison as to the relative cost of operating a cable and a radio system may be gathered from the figures quoted by an Australian radio company, which plans to give a radio telegraph service between Australia and England, at one-third less than the cost of cable communication. The cost of establishing this service would be roughly \$5,000,000, of which the company already has about half that amount.

### Radio Calling Apparatus

FROM France comes the news that L. Chauveau has developed a simple and reliable system whereby a radio operator may call up a certain person or station, in order to compete with ordinary wire telephony and telegraphy. This French inventor claims to have solved this problem and gives a description of his automatic radio calling apparatus in a recent issue of *Radioelectricite*. It consists of a combination of twenty magnetic relays—ten corresponding to "dot" and ten to "dash" calls, as well as a time relay. The apparatus can be set for any combination up to five letters or numerals, and if the call arrives in proper sequence and at proper time intervals, the last relay will close a signalling circuit, notifying the attendant of the receiving station. To ensure the essential accuracy of sequence and time, the sending station emits the call with a mechanical caller.

### The Airplane and the Radio Beacon

WITH the rapid strides now being made in commercial aviation throughout Europe, the matter of radio beacons, as radio compass installations are called when employed to guide aircraft,

is an important one. It seems now that in the very near future there will be automatic radio telegraph transmitters located at regular intervals along air routes for the purpose of transmitting characteristic signals whereby any aircraft pilot can secure his bearings by checking up on two or more radio beacons. For the present, aircraft pilots depend on the usual radio stations, whom they ask for information concerning their bearings. In the future, the airships and airplanes will probably carry their own radio compass installations and will have to figure out their own bearings.

### The British Mullard Tubes

IN THE United States we think of Radiotrons when we turn to vacuum tubes, not that there are no other tubes to be had, but because the Radiotrons are in such general use. In England, on the other hand, the amateurs think of Mullard radio valves. The British amateur makes use of the Mullard tubes made for receiving purposes. These tubes, or valves, as they are called, are made in a variety of types. The most common type is the type R, which has an overall length, including pin contact members, of  $4\frac{1}{2}$  inches and a bulb diameter of  $2\frac{1}{4}$  inches. It works best on a filament voltage of 4, and 60 to 80 volts between the plate and the filament. In the K type, which is somewhat more compact, about  $3\frac{1}{2}$  volts is required for the filament, and 20 to 30 volts for the plate circuit. This particular type is suitable for use in radio frequency amplifiers. The D type is a slightly soft tube designed for use in detecting or rectifying signals prior to audio-frequency amplification. It operates best at about 5 volts filament current, and 20 to 30 volts for the plate circuit. The electrodes of the Mullard tubes are made from sheet nickel, and molybdenum and tungsten wire. The Mullard valves or tubes for transmitting purposes have bulbs made with silica, which not only reduces the danger of breakage but also permits of bringing the container nearer to the filament and grid so as to reduce the size of the tube.

### The England-Egypt Radio Link

COMMUNICATION has been established between the Leafield (Oxfordshire, England) and the Abu Zabal (Cairo, Egypt) stations, but no commercial facilities are yet available, according to latest advices. In reply to a question in the

House of Commons recently, the Postmaster-General said that experimental transmission had been commenced between the two stations and as soon as the preliminary trials were completed a public service would be inaugurated. The Leafield station had been working satisfactorily for some months, and its messages were regularly picked up practically all the way by liners on the Australian route. The total cost of these two stations was estimated at well over \$1,000,000. The cost of the remaining stations of the Imperial Chain is estimated at well over \$4,000,000, but without provision for patent royalties.

#### Some Applications of the Vacuum Tubes

**P**ROBABLY no piece of electrical apparatus is so adaptable to a variety of purposes as the three electrode vacuum tube, and this with little or no modification of its construction. This wonderful adaptability is well illustrated in the high-speed transmitting and receiving equipment recently described by Lieut.-Colonel Cusins in his paper before the Wireless Section of the British Institution of Electrical Engineers. The transmitter and receiver contain together eleven tubes, which have, between them, eight different functions to perform. Of the two in the transmitter one is the main high-frequency generator while the other acts as a variable control resistance in its grid circuit. In the receiver, three serve as a radio-frequency amplifier, one as a tube relay, one as an audio-frequency generator, one as a tube-relay control valve, one as a direct-current amplifier, and two in conjunction as a double-current valve relay. Although the paper described the progress made in what the author called the mechanicalization of wireless telegraphy, this progress is only made possible by the elimination of mechanical links, except at the beginning and end of the chain, and their replacement by three-electrode vacuum tubes.

#### Radio Telephones on German Railroads

**W**HILE the idea of using radio telephones on railroads is not altogether new, all previous attempts along this line have not proved successful, for the simple reason that no suitable form of wave generator was available, and the receiving equipment was relatively crude. Now with the vacuum tube available for receiving and transmitting, it becomes possible to utilize

radio telephony for railroad purposes. It is reported that several German express trains are to be equipped with radio telephones to provide communication between the passengers and hotels and stations.

#### Radio Telephony in Sweden

**T**HE telegraph authorities of Sweden are now conducting experiments for linking up the ordinary telephone with the wireless telephone so as to enable through calls to be effected. This scheme of using radio links, as radio telephony is called when employed in conjunction with regular telephone systems, has been tried out in the United States with promising results, and there is a radio link connecting up Santa Catalina Island with the California mainland in everyday operation.

#### Northern Africa Radio Station

**T**HE building of the radio station at Ain-el-Hadjar, near Saida, on the railway line from Perregaux to Colomb-Bechar, has just been started by a detachment of military engineers. The station, which will be the most important in North Africa, is intended to form the radio link between France and her African colonies, and in case of a breakage of the submarine cables to undertake the forwarding of telephone messages between France and Algeria.

#### Radio Service for British Columbia

**T**HERE has been established at Vancouver a radio telephone service for British Columbia, interior and coastwise, and for deep-sea ships as far as 2,500 miles at sea. It is planned to give the world news, concerts, and speeches to distant parts. The tests have been successful, and the station is now in regular operation.

#### When Wireless is Better than Wires

**E**STABLISHMENT of radio stations at Stewart, Atlin, and Alice Arm, in British Columbia, and Dawson and White Horse, in the Yukon, will be urged upon the Canadian Government by Frederick Stork, member-elect for Skeena Riding. According to Mr. Stork, the cost of installing radio would be very small compared with the amount required to put the old telegraph line in shape, and would insure a service that would be in operation at all times.

# Objects That Distort Radio Waves

Tests Show that Electric Wires or Cables, Steel Structures, Rivers, Trees, Trolleys, Tennis Backstops, Antennas, and Stone and Iron Monuments All Affect the Direction of Radio Waves

By L. E. WHITTEMORE

U. S. Bureau of Standards

ANY one who has thrown a stone into a pond of water knows how the waves spread in all directions from the spot which the stone strikes. The front of the wave moves along always remaining in the same position perpendicular to the line from the centre of the circle passing out in the direction of travel. This uniform position of the front of the water wave remains until the wave strikes a rock or a stick, or is led down a small channel or bay. Then the direction changes, and the wave takes a position which depends upon the size and nature of the obstacle which it encounters.

Similarly, radio waves spread out in all directions from the antenna of an ordinary radio transmitting station. The direction of the front of the wave is constant and is perpendicular to the line of advance of the wave unless some obstacle is encountered, or the wave strikes some new substance which causes it to change its speed or the velocity of transmission.

The things which may cause changes in the direction of radio waves are usually objects made of metal. Thus any electric wires or cables or any metallic structure, such as the steel frame of a large building, are likely to cause the direction of the radio waves to change as they travel along the surface of the earth. Even rivers and possibly trees during the spring when the sap is running may affect the direction of the passage of radio waves.

A comparison may be made with the waves of light which are transmitted from any object which we are able to see. The light waves ordinarily travel in a straight line, but when they strike some irregular piece of glass they are bent from this straight line. A familiar example is the bending of rays of light by the use of a glass prism or lens. Everyone is familiar with the distortion of light waves caused by a glass of water. A coin or other small object placed in the glass appears, when

seen through the water, to be in some position other than its real position.

If no objects are in the path of the waves to cause a change in the direction of the front of the wave, one can tell from the position of this wave front the direction from which the wave has come. In the case of the water waves this means the spot where the stone struck the water; in the case of the light waves the luminous object or source of light; and in the case of the radio waves the radio transmitting station.

If a small stick were thrown on the water in the region through which the water waves are traveling, this stick might happen to lie in a direction along the front of the wave. It would then move up and down as a whole, first riding on the crest of the wave and then riding in the trough of the wave. If the stick happened to be turned in the other direction, it would bob up and down, one end rising while the other end falls. In this case it would be lying across the line of the wave front, but exactly in line with the direction in which the waves are moving. It is conceivable that such a stick might be used by someone who could not see the water waves, but who could tell by means of his sense of touch by feeling the motion of the stick the direction in which the water waves were traveling.

If one cared to determine the direction from which light waves were coming, he could take a hollow tube and look through it as he turns it around. If the same amount of light were visible when one looked through either end of the tube, this tube would then be parallel to the front of the light wave. If as one looked through the tube he saw the light very brightly from one end, but saw no light from the other end, the tube would be across the line of the wave front and in line with the direction of transmission of the light waves. Thus the hollow tube could be used as a direction finder for sources of light. Actually we do not have

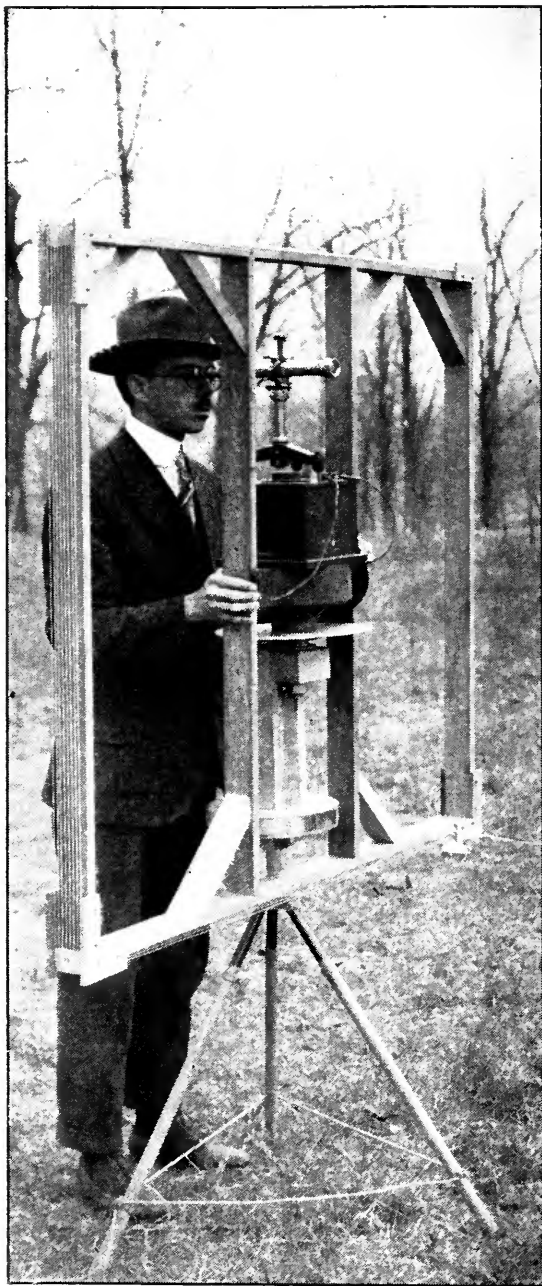

Radio direction finder frame on which telescope is mounted for use in sighting on the radio transmitting station. The scale of degrees is the circular disk just below the hand of the observer

to go through such a complicated procedure to learn the direction of sources of light waves because the human eye is itself an almost perfect direction finder for sources of light waves on account of its highly developed sense of sight.

We do not have physical senses which enable us to feel or see actually the direction from

which waves reach us from a radio transmitting station, so it is necessary to use a device which will give us some effect which can be observed through one of our senses, and this effect must be different when the device used is in the line of the front of the radio wave from what it must be when the device is perpendicular to the front of the wave or in line with the direction in which the wave is carried or transmitted along the surface of the earth. Such a device is found in one of the many types of antennas used for receiving radio signals.

When this type of antenna is used with the proper tuning and other receiving apparatus, it changes the energy carried by the radio waves into sound which can be heard by our ears. An antenna which is conveniently used in this way is made by winding a few turns of wire upon a frame a few feet square. The ends of this coil are connected to the rest of the receiving apparatus. When the coil is in the general vicinity of the radio transmitting station it is found that the signals which one hears are louder or weaker, depending upon the position of this coil antenna when turned about a vertical axis. When the coil is parallel to the front of the radio wave, there is little or no response, that is, one hears no radio signals. When the coil is perpendicular to the front of the radio wave, but is turned in the line of direction of transmission of this wave, there is a maximum response, that is, loud signals are heard. Therefore a coil antenna is a direction finder which will enable one to determine the direction of a radio transmitting station which is the source of radio waves. A common form of direction finder for use in receiving from the present day radio telephone broadcasting stations is a coil of about six turns of wire wound on a frame four feet square.

All practical uses of the radio direction finder require that it be connected to a sensitive detector and amplifier in order to secure reasonably loud signals. This is necessary because of the small size of antenna which can be conveniently turned around in one direction or another. The principal practical uses of the radio direction finder in radio communication are:

(1) Its use on shipboard as an aid to the navigation of the ship.\* By its use the captain of the ship may tell the direction to a transmitting station located at a lighthouse.

(2) Its use at a radio station along the coast for determining the direction to a ship which

\*See Bureau of Standards, Scientific Paper No. 428.



may be transmitting distress signals or which desires to learn its position.

(3) Its use on aircraft for enabling the pilot to tell the direction to a landing field. It is often impossible to see the ground from airplanes which are carrying mail or which are engaged in commercial business and must, therefore, fly under all weather conditions. The pilots of airplanes are always anxious to know the exact direction to the closest landing field in order that they may come safely to the ground in case of need.

(4) Its use on the ground at landing fields for aircraft to tell the direction of aircraft in flight which have on board radio transmitting equipment.

(5) Its use at a station engaged in ordinary radio communication. Such use takes advantage of the fact that transmitting stations

in one direction produce very weak signals, while transmitting stations in another direction may be heard very clearly.

(6) Its use as the antenna of a small portable receiving station, such as may be carried in an automobile or by hand.

For all of these uses it is important to know whether the direction finder is accurate in its indications. A calibration can be made which, when applied to the readings of the direction finder, makes its use entirely practical.

Such a study of the accuracy of a radio direction finder has been conducted by the United States Bureau of Standards of the Department of Commerce. The radio engineers connected with the radio laboratory of the Bureau of Standards have conducted a series of experiments to determine what kinds of objects cause serious change in the

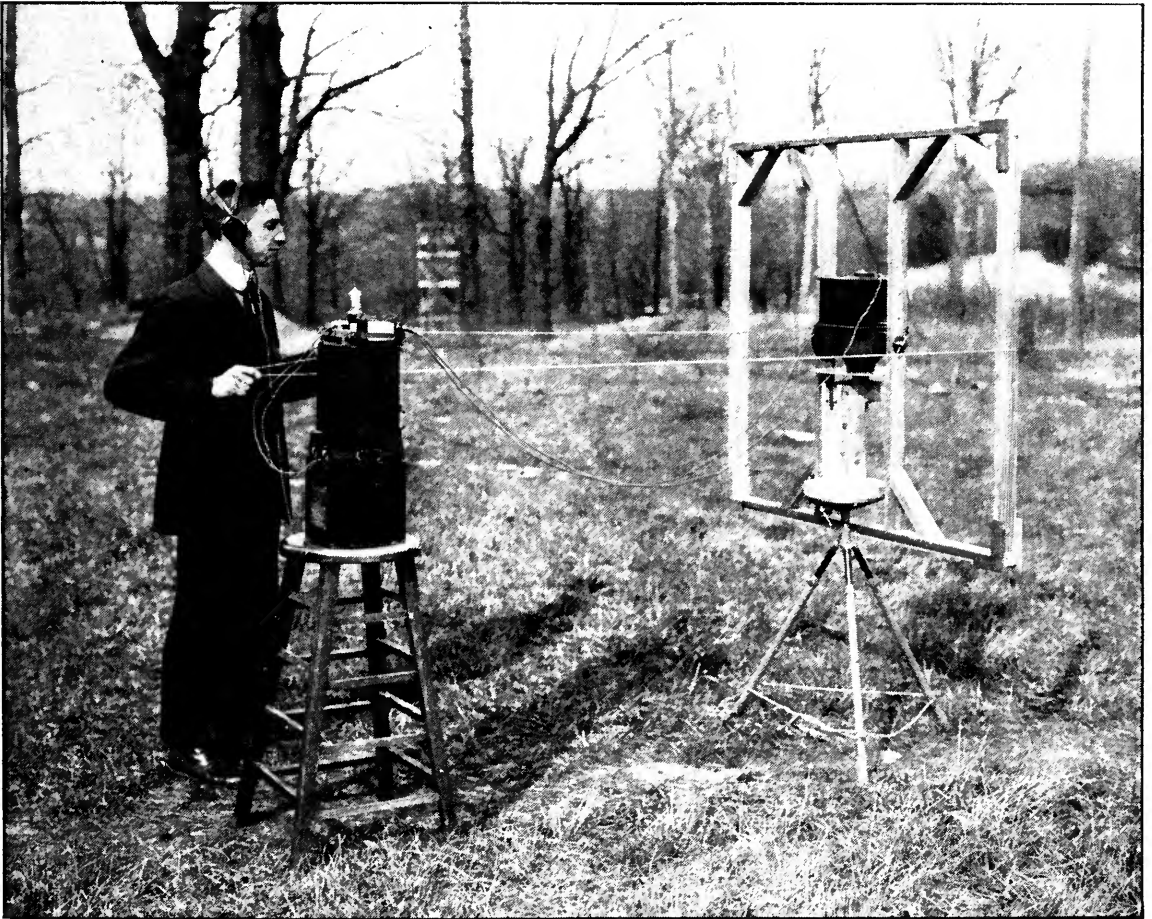

Radio direction finder in use in obtaining exact position of passing radio waves. The observer turns the frame by means of cords in order to be sure that his body has no effect on the direction of the waves. The detector and batteries are seen on the stool near the operator

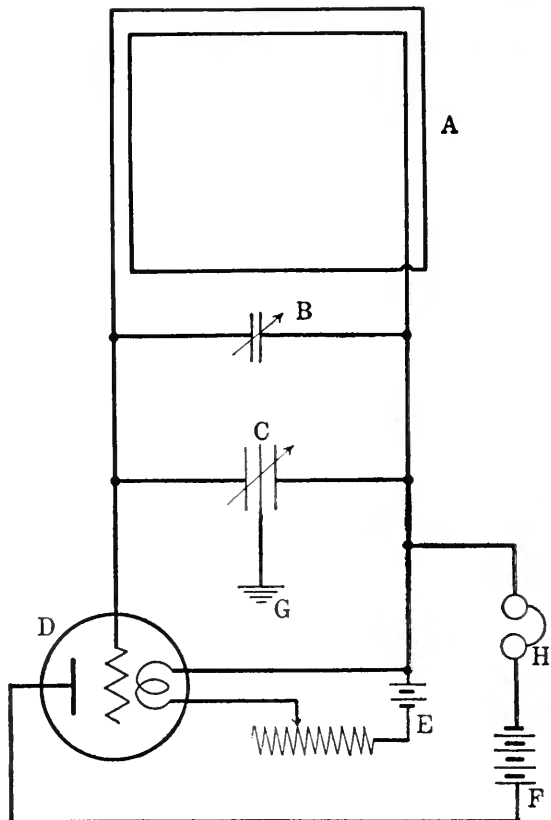

Circuit diagram of radio direction finder. A is the direction finder coil, B the tuning condenser, C the Mesny compensating condenser used for obtaining sharper indication of direction, D the electron tube detector, E the filament battery, F the plate battery, G the ground connection, H the telephone receiver

direction of radio waves and what precautions should be taken in using the radio direction finder in order to be as sure as possible that the direction obtained is the correct one. It was soon learned that the direction of the radio waves was noticeably different when the direction finder was placed near large metal bodies than when the direction finder was located in a large open space. But if this change in direction is once definitely determined for given conditions, it can be used in interpreting and making entirely correct the observations subsequently made in the use of the direction finder in practice. The most complete series of experiments was conducted on land with a portable direction finder and receiving set which could be taken to a large variety of places to determine the direction and amount of various individual cases of radio wave distortion.

The direction finder was fitted with a scale

for reading the angular position of the frame on which the coil was wound. This frame was also fitted with a telescope for use in securing a direct view of the radio transmitting station and thus determining visually the true direction. The coil wound on this frame was connected with the necessary tuning condenser, detector, amplifier, and telephone receivers for hearing the radio signals sent out from the radio transmitting station. A radio transmitting station was installed in one of the buildings of the Soldiers Home located in the northern part of the District of Columbia. This location was selected because the tower which supported one end of the transmitting antenna was visible from most points in the District of Columbia. The transmitting station was equipped with electron tube apparatus for sending out interrupted continuous waves. It was also arranged to transmit automatically a series of long dashes for use in making the tests of direction.

The receiving apparatus was so assembled as to be conveniently moved by motor truck to various points in Washington, D. C. The places selected were in open regions so far as possible with only one rather simple object near by which might cause the radio waves to change their direction in their passage through that vicinity. In taking readings, the direction finder frame was turned until the transmitting station was seen through the telescope. With the frame held in this position the scale was turned until the pointer read zero. The receiving operator then listened to the radio signals which were being transmitted at that time. He turned the direction finder frame until the signals were weaker than for any other position of the frame. The direction finder was then in the line of the wave front and the reading of the pointer on the scale was observed. If there were no objects causing any distortion or change in direction of the radio waves, this radio scale reading was zero, that is, the same as the scale reading found after the visual observation. If any difference was found between these two readings it showed a change in the direction of the radio wave from the true direction to the transmitting station. As the direction finder was moved nearer to or farther from the object being tested, the distortion or change in direction of the waves became greater or less.

Near the trolley wire of an electric interurban line the direction finder sometimes showed that

the waves were distorted as much as 50 degrees, while at greater distances from this same trolley line the distortion became less until at points about 2000 feet away the distortion was entirely gone. This means that after passing a distorting structure the waves straighten out again and are not erroneous in their direction until other obstructions are met. It was found that the amount of distortion produced varied sometimes as a trolley car passed along the line and thus changed the point at which the trolley wire was connected through its motor to the ground.

Near a large screen, such as is used as backstop for a tennis court, or near a large tree in an open field it is found that the distortion is in one direction when the direction finder is on one side of the object, while the distortion is in the other direction when the direction finder is on the other side. The distortion or bending of the waves is also found to differ when the transmitting station uses different frequencies or wave lengths. The wave length, which is subject to greater bending, depends upon the actual dimensions of the object which is causing this change in direction. When the direction finder was located on a large concrete bridge having steel reinforcement, a change in the direction of the radio waves amounting to as much as 14 degrees was observed. This bending of the waves became less as the direction finder was moved along the road away from the bridge in either direction. The distortion was found to be worse when the transmitting station was using a wave length of 400 meters than when it used longer waves. Similar results were obtained when the direction finder was placed in the vicinity of a telephone line or a low antenna of an ordinary radio receiving station. The distortion became greater as the direction finder was brought nearer to the wire. The distortion was in opposite directions as the radio direction finder was used at the two opposite sides of the wire, telephone line, or antenna. In the case of the antenna the distortion was found to be far greater when the antenna and receiving set system were tuned to the same wave length as that employed by the transmitting station whose signals were being observed.

Among the most interesting tests of this series were those made in the vicinity of the Washington monument. This monument is built of stone, but contains an iron stairway and an elevator cable which are conductors

of electric current. The Washington monument is 555 feet in height and is located in the centre of a large park which is comparatively free from other structures which might cause a change in the direction of the passing radio waves. By far the greater distortion of the waves was observed at points near the monument, changes of direction as large as 70 or 80 degrees being found at points as near as 150 feet to the base of the monument. When the direction finder was moved to a point 300 or 400 feet from the base of the monument the distortion was found to be only 5 or 10 degrees.

In order to determine the wave length at which the monument caused the greatest

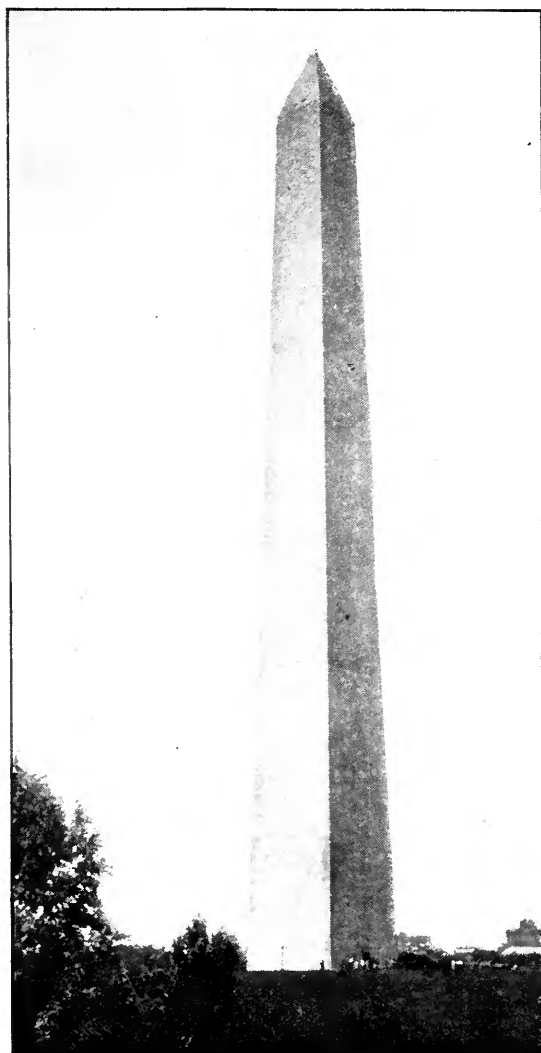

Washington monument around which tests of the direction of radio waves were made. The natural wave length of the monument was found to be about 800 meters

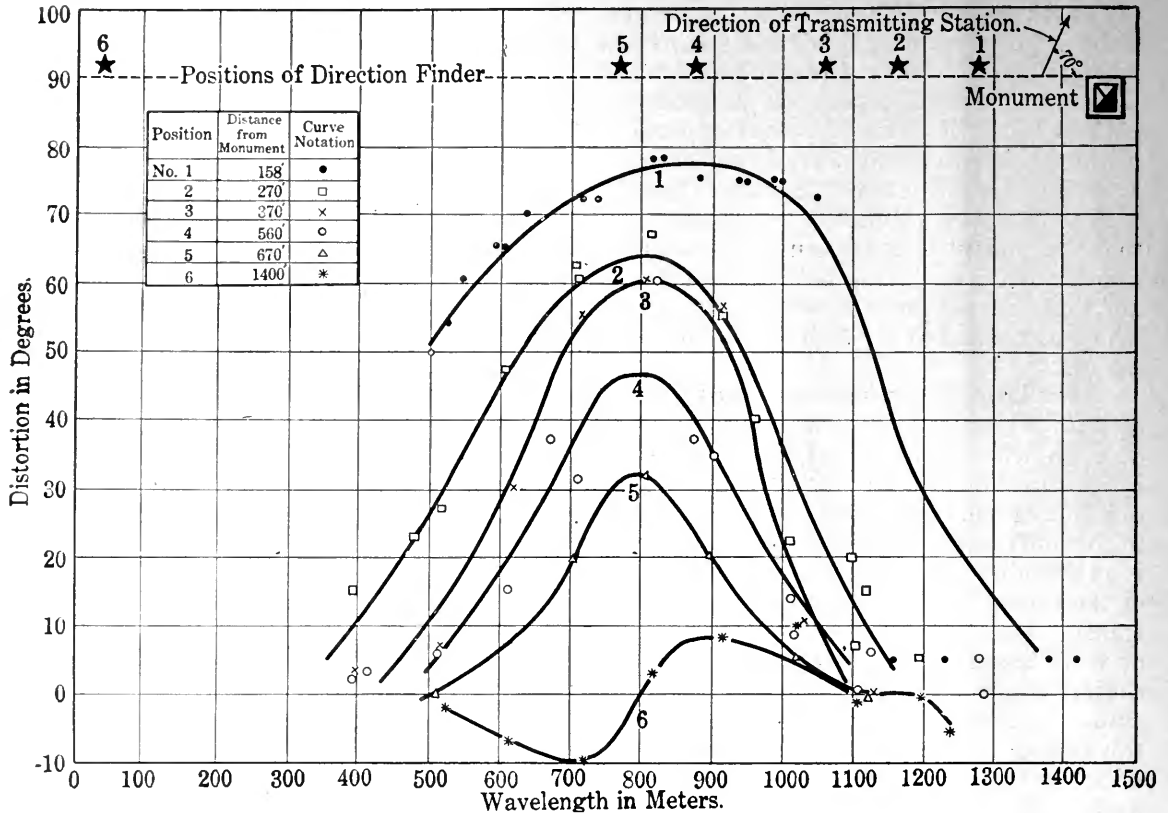

Distortion of radio waves of various lengths caused by the Washington monument. The closer the location of the direction finder to the monument, the greater the distortion at any point. The distortion was greatest when the transmitting station used a wave length of 800 meters

change in wave direction, signals were transmitted from the Bureau of Standards station at the Soldiers Home on a series of waves ranging from 400 to 1400 meters. The direction finder was placed successively at each of a number of positions at increasing distances from the monument. Measurements were made of the bending of the waves which was observed at each of these positions and for each of the wave lengths of transmission. It was found that while the bending of the waves was greater at the points nearer the monument, the distortion observed at a given location of the direction finder increased as the length of the transmitted wave was raised above 400 meters, until the wave length 800 meters was reached. At this wave length the angular distortion of the waves

was greatest, and when longer wave lengths were used by the transmitting station the distortion became very much less. It was therefore conclusively shown that the Washington monument was most effective in changing the direction of waves of 800 meters length. If the monument is considered as a simple radio antenna, it is found that the length of the waves which it would send out if it were used as the antenna of a transmitting station would be approximately 800 meters. Thus it may be seen that the distortion caused by a given object is greatest when the waves which are passing by it are of the same length as those which would naturally be sent out by that object if it were used as the antenna of a transmitting station.

# Tuning the Radio Aerial System

By JOHN V. L. HOGAN

Consulting Engineer; Past President and Fellow, Institute of Radio Engineers

IT HAS been pointed out\* that interference cannot be eliminated, even with the best radio receivers. Very intense interfering waves from powerful or nearby transmitters are likely to break through the barriers erected by the most highly selective receivers; if the interference is from a poorly designed or poorly adjusted sending plant, to exclude it from the receiver is found well-nigh impossible.

This situation does not argue against the adoption and use of sharply tuned receiving instruments, however. One would be greatly in error if he were to conclude that, since no known receiver (however nearly perfect) will prevent all interference difficulties, he might as well use a non-selective apparatus. A receiver which has the capability of close and exact adjustment to desired wave frequencies (or wave lengths) will invariably aid in minimizing interference effects; with it one will be able to receive clearly under many conditions where a broadly adjusted receiver would be helpless to discriminate between desired and undesired signals.

Now, what is it that makes one receiver "sharp tuned" and another "broad tuned?" How does it happen that a sharply adjusted or selective receiver will distinguish between arriving radio waves of only slightly different frequencies? Why does a broadly tuned instrument accept with almost equal ease signals whose frequencies are entirely different? The replies to these questions include nearly the whole subject of tuning at radio receiving stations. As a first step toward answering them, let us consider what happens when radio waves reach an intercepting aerial and the associated instruments.

Figure 1 is a diagram of a simple tuned receiving system. The aerial wires, which may be any of the familiar forms now seen throughout the country, are represented by the pitchfork symbol at the top of the drawing; a connection leads from the aerial downward to the inductance or tuning coil within the radio station. As indicated, this coil may be wholly or partly connected into the circuit by means of

movable tap reaching successive turns. From this variable connection a wire extends farther downward through a sensitive current measuring instrument and thence to the ground connection.

When radio waves pass any receiving aerial wire system, they automatically and inevitably generate in that system a series of rapid alternating electric voltages (or electric pressures tending to cause a flow of electric current). If the aerial wire is connected to the ground, as in Fig. 1, the high frequency alternating voltages will produce a series of small but measurable

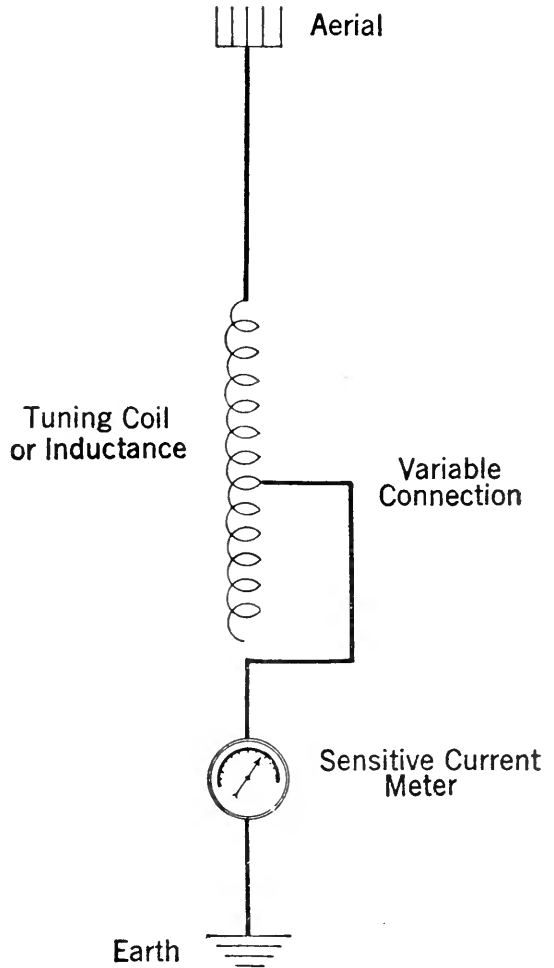

Fig. 1

\*"Interference in Radio Signaling," by John V. L. Hogan, RADIO BROADCAST, May, 1922, p. 5.

electric currents flowing in the aerial-to-ground circuit. These currents will alternately flow up and down, the frequency of complete (double) reversal being identical with the frequency of the arriving radio wave. The currents will last as long as the radio waves continue to strike the aerial; when the wave ceases, the currents will rapidly die away.

It should thus be evident that if a stream of radio waves having a length of 360 meters, and

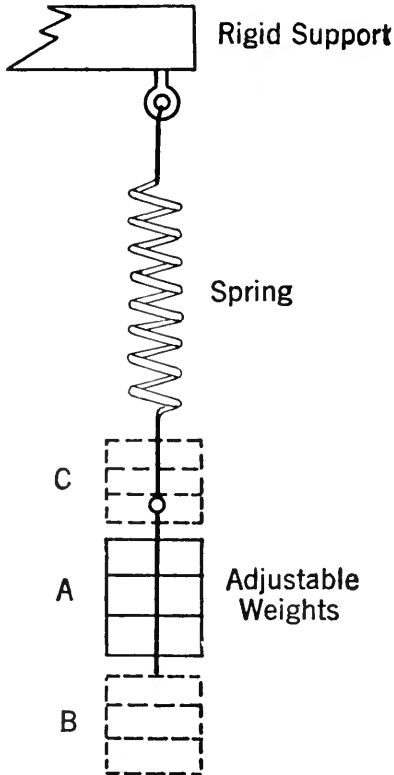

Fig. 2

therefore a frequency of 833,000 cycles per second, impinges upon the aerial of Fig. 1, there will be set up in the aerial wires an alternating current of the same frequency, viz. 833,000 cycles or complete reversals per second. This current will flow between aerial and ground through the tuning coil and meter shown, and, if the meter is of proper delicacy, will register its passage by moving the pointer. Similarly, if a 375 meter radio wave strikes the aerial, it will generate an 800,000 cycle current which will also flow through and be indicated by the meter. Supposing that we desire to receive the signals carried by the 833,000 cycle wave and current, and to exclude the signals of the 800,000 cycle interfering wave, it is clear that

we must find some method of augmenting the effects of one while reducing those of the other.

There is a practical scientific way of selecting electric currents of any one frequency at the expense of those having different frequencies. The method is based upon electrical resonance or tuning, and is analogous to the phenomenon of "sympathetic vibration" which is so well known in the field of music. It depends simply upon securing an agreement between the frequency of the driving forces (the radio waves, for instance) and the most-easily-assumed or "natural" frequency of the driven system (in our example, the antenna-to-ground circuit). When these frequencies are alike they are said to be tuned to or resonant with each other.

A digression will, perhaps, aid in securing a vivid idea of this natural or most-easily-assumed frequency of vibration. It is easy to grasp the thought of natural frequency of mechanical vibration in, for example, such an arrangement as is shown by Figure 2. Here a weight is supported by a coiled spring. At rest the weight takes the position A, where it is shown in full lines. If it is pulled down to position B and released, it will bob up and down between B and C, the path of travel gradually growing less and less until, finally, it will come to rest at the original position A. Perhaps the most interesting thing about such a system is that the number of times the weight will bob up and down again per second or per minute (in other words, its natural frequency of vibration) will be the same for every swing, regardless of the distance the weight moves in any one vibration. The most effective way to change this natural frequency of vibration is to change the stiffness of the spring or the mass of the weight. As can be easily seen, the greater the mass, the more slowly the system will oscillate; similarly, the greater the "flimsiness" of the spring, the more slowly will the weight move up and down. As these two factors (or either of them) increase, therefore, the frequency of natural vibration decreases. By changing either the weight or the spring one can make the frequency of the system anything he desires, within structural limits.

Suppose that when disturbed and left to oscillate the weight rose and fell, or executed a complete up and down movement, four times per second. The system would then have a natural frequency of four cycles per second.



This frequency is called "natural," because it is that of the system vibrating naturally or freely, without any external influence. If, now, one grasped the weight and used sufficient strength, it would of course be possible to force it to move up and down at a different rate, say once, or even ten times, per second. But this frequency would be *forced* frequency of movement, not a natural one. We may now consider the phrase "most-easily-attained" frequency used above. If one begins forcing the weight of this particular spring pendulum up and down at one cycle per second, and then gradually increases the rate of motion, he will find that as he approaches closer and closer to the natural frequency of four per second he will need to exert less and less effort to keep the weight swinging. At the exact natural frequency a mere touch for each vibration will maintain the oscillation; the spring and weight will seem to work together to keep on going at this particular rate. On the other hand, as it is attempted to move the pendulum faster and faster, at frequencies increasingly higher than four per second, the work required will be harder and harder. Thus, the natural frequency of four per second is the most easily attained frequency of vibration.

An entirely similar set of conditions holds for an electrical circuit containing elements such as coils and condensers, which possess the electrical properties of inductance and capacitance. We may set up such a circuit, as in Fig. 3, and charge the condenser (which need consist merely of two plates of metal hung face to face and close together in the air), by connecting to it a high potential battery. On removing the battery, the condenser will discharge through the coil, producing an alternating current which will swing back and forth at the natural frequency of the circuit. The frequency of this electrical oscillation can be changed at will by increasing the size of the condenser (i. e., its electrical capacitance) or the size of the coil (i. e., its electrical inductance). Varying these constants corresponds exactly to changing the flimsiness of the spring or the mass of the pendulum bob, in the analogous mechanical system previously described. So we have a way to control the natural or most easily attained electrical frequency of a condenser-coil circuit.

The condenser of such an electrical oscillatory circuit need not be of the ordinary plate-to-plate type. An aerial wire system acts,

opposite to the ground below it, like an electrical condenser. The elevated wires constitute one "plate" of such a condenser and the earth forms the other; the two possess electrical capacitance with respect to each other.

With the above in mind, and returning to the electrical system of Fig. 1, let us imagine that a stream of radio waves having 833,000

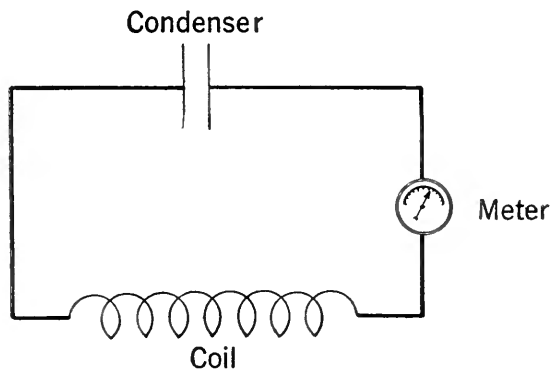

Fig. 3

cycles frequency strikes the aerial and induces corresponding voltages therein. Let us assume that the tuning coil has been adjusted so that its inductance, taken together with capacitance of the aerial system, gives to the circuit a natural frequency of the same value, 833,000 cycles per second. Reasoning that the induced voltages correspond to the hand driving the spring pendulum and that the resulting currents correspond to the motion of the pendulum weight, one would expect this agreement between arriving wave frequency and most-easily-attained circuit frequency to result in the largest possible radio current flowing in the aerial-to-ground system. This is the fact, as we may determine by a relatively simple test.

Consider that the frequency of the arriving waves falls slightly below 833,000 cycles per second, say to 831,000 cycles. The voltages in the aerial, and the currents produced thereby, will have this same lowered frequency of 831,000 cycles. But if the receiver is unchanged, this will no longer be the natural frequency, to which the system most easily vibrates; consequently not so much current can flow between aerial and ground. The same reduction in current would occur if the arriving wave frequency were slightly increased, say to 835,000 cycles per second. The greater the departure from the resonant condition attained at 833,000 cycles, when the arriving and natural fre-

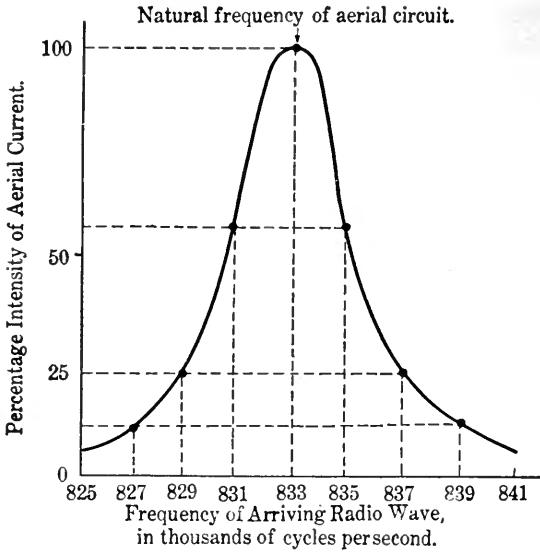

FIG. 4

quencies agree, the less the current which will be produced in the tuned aerial circuit. This is clearly shown in Fig. 4, where frequencies

differing by 4000 cycles above and below are seen to produce only about 25 per cent. of the maximum or resonant current value. A graph of the sort reproduced as Fig. 4 is called a resonance curve, since it shows how changes in frequency above and below the resonant value result in a diminution of the current to be indicated. A little study will make clear that the steeper the sides of such a resonance curve, or the sharper its peak, the greater will be the frequency-selecting power of the circuit it represents.

Evidently the adjustable resonant circuit gives us a powerful weapon against the evil of radio interference. By setting our receiver's natural frequency to agree with the frequency of the arriving wave to which we desire to listen, we automatically make our instruments less receptive to interfering waves of other frequencies. It is merely essential that we use circuits whose resonance curves are sharply peaked if we are to get the highest degree of resonant selection.

## What Receiving Set Shall I Buy?

A Survey of the Current Offerings and When and How They Should be Employed to Receive the Radio-Phone Programmes

By J. CONRAD FLEMMING

THE selection of a radio receiving set should be quite as simple a matter as the selection of an automobile, piano, phonograph, furniture, suit, hat, or whatnot. The only reason why it appears more difficult is because the average layman knows less about radio than he does about other things—for the time being, at least. But if one becomes even superficially acquainted with radio and the requirements of radio reception, the selection of a radio receiving set for any given circumstances becomes just as simple and as positive as the selection of a rug to match the color scheme of a given room.

Behind all receiving sets there is one fundamental factor which affects the selection of the proper type for a given bit of work, and that is the distance between the receiving station and the transmitter which is to be heard.

The radio waves which travel out in all directions from the radio-phone broadcasting station become weaker and weaker as they reach farther and farther away from the transmitter, and in due course they become so weak that they no longer affect even our most sensitive receiving sets, so that to all intents and purposes they are non-existent. But in theory the waves go on for ever, becoming weaker and weaker and still weaker, but never reaching the zero beyond infinity.

Now receiving sets are of varying degrees of sensitiveness. Thus an inexpensive outfit must receive a certain amount of radio energy before it will respond and give satisfactory strength of music or speech in the telephone receivers. A more expensive outfit has a better means of using the intercepted wave energy to the utmost extent, so that it will respond satisfactorily with a far weaker wave

than is the case with the cheap outfits. A still more expensive outfit, provided with wave amplifying and sound amplifying accessories, responds to even weaker waves still, so that it operates at great distances when the waves have become so weak or attenuated that they are no longer detected by the cheaper outfits. So it is a case of using a receiving set that is sufficiently sensitive to make use of such radio waves as are intercepted in any given locality.

Thus it comes about that the person located in a city near a broadcasting station can employ a very inexpensive set with excellent results. On the other hand, the farmer, some 100 miles away, must employ a set costing ten times as much to receive the same broadcasting service. The cheap outfit does just as well as the expensive outfit under these circumstances; the farmer is simply paying for the distance which he has to span with his receiving set.

The usual method of intercepting radio waves is to use what is known as the antenna. This is simply one or two wires elevated a certain distance above the ground, and carefully insulated so that such wave energy as these wires intercept will not escape or leak before it can be brought to the receiving set.

The antenna should be at least 50 feet long, and for the best results, it should be at least 125 to 150 feet long. If the antenna is made longer than 150 feet, little is gained because it then becomes too long for the short wave length of radio broadcasting stations, and auxiliary apparatus must be employed to reduce the wave length of the antenna.

From the single- or double-wire antenna, a single- or double-wire arrangement is led down to the room containing the receiving instruments. This is known as the lead in. This wire is connected with the receiving set. Another connection is made between the receiving set and the ground, which may be a water pipe, a steam pipe, or a gas pipe, just so long as these pipes are known to be connected with the ground. In the country, where water pipes, gas pipes and steam pipes are not available, it is necessary to drive a length of iron pipe into damp soil, bury a copper or zinc plate in damp soil, or, again, to connect a wire to a pail which is lowered into a well or other body of water.

The antenna arrangement is mentioned in the foregoing only because it plays an important part in the selection of a receiving set. Other articles which are appearing in these

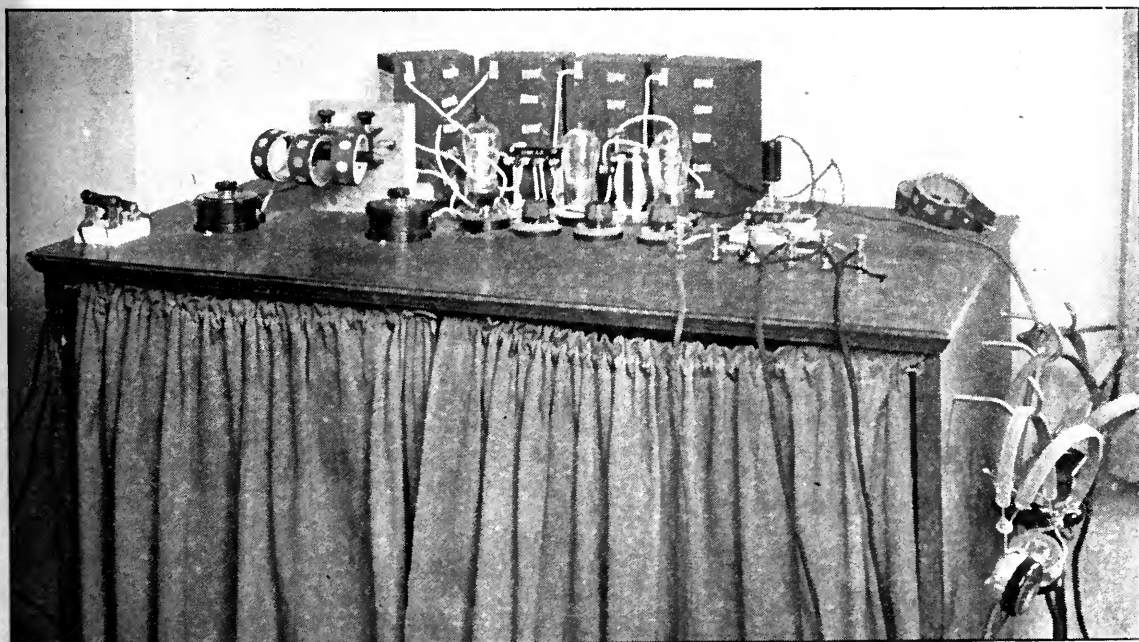

A receiving outfit of which the parts are screwed to a table top, and reduced to simple form. At the extreme left is the A battery switch; then come the duo-lateral coils, the primary and secondary condensers, and the detector and amplifier bulbs with their accessories. The six binding posts on the right are so arranged that three head sets may be connected at one time. Behind them is a double-throw switch for cutting in the loud speaker



Although told that it could not be done, this radio enthusiast operates a loud speaker downstairs from his upstairs receiving set, the two being connected by seventy-five feet of flexible cord

columns have more to say regarding the erection of the antenna and the arrangement of the ground connection.

The first consideration in the purchasing of a receiving set is to decide just what broadcasting stations are to be intercepted and how far away they are located from the proposed receiving station. The second consideration is how big an antenna can be erected. Naturally, since the antenna decides how much radio energy is intercepted, the smaller the antenna the less the radio energy intercepted, and therefore the better the receiving set must be to operate over a given distance.

For receiving over distances of less than twenty-five miles, with a good antenna measuring 100 feet or more in length, elevated at least 20 feet above the ground or the roof of a house if it happens to be installed in a city apartment house, any one of the several inexpensive receiving sets, selling for about \$15.00 to \$25.00 will give satisfactory results. These sets generally consist of a simple tuning device, which permits of adjusting the set to any desired radio-phone station or radio telegraph transmitter within range, a simple crystal detector, and a pair of telephone receivers.

The crystal detector is the device which converts the intercepted radio energy into audible sounds in the telephone receivers. It is the simplest kind of radio detector, requiring no battery of any kind for its operation. However, its sensitiveness is rather limited, so that for distances greater than twenty-five miles it is of little value.

With inexpensive sets good results may be obtained from near by stations, but the impossible should not be expected. Thus it would be sheer nonsense to expect to operate a loud-speaking horn with a cheap outfit. Such loud-speaking devices, which make the radio receiving outfit somewhat akin to a phonograph in point of convenience and loudness, can only be used with the most expensive types of receiving set. Furthermore, only one pair of telephone receivers should be used with an inexpensive outfit, because the amount of converted energy is very small, and an additional pair of telephone receivers cuts down the sound strength. Still, two pairs of receivers may be used if necessary.

If louder music or speech is desired, even within a distance of twenty-five miles, it is necessary to turn to the more expensive offerings, in which the crystal detector is replaced by the vacuum tube. The vacuum tube detector resembles nothing so much as an electric lamp. It is provided with a filament, which glows like that of any electric lamp. However, it contains two other members, namely, a little helix or coil of wire which is known as the grid, and a cylindrical member known as the plate. The action of the vacuum tube is quite involved as far as the theory is concerned, but in practice it proves to be a far more sensitive device than the crystal detector.

The crystal detector, as already mentioned, requires no battery. The vacuum tube, on the other hand, requires two batteries, namely, a filament battery, and a high-voltage plate battery or "B" battery, as it is called. The filament battery must be capable of supplying current to the filament for a long period of time. Most vacuum tubes require a potential of five to six volts and a current of one ampere for the filament, so that this heavy drain necessitates the use of a storage battery. For that reason many persons hesitate to employ a vacuum tube set because of the expense of purchasing a storage battery, and also because the storage battery must be watched and tested at intervals to determine when it

is run down and when it requires recharging. However, there are now available on the market certain vacuum tube sets which make use of special vacuum tubes which operate on  $1\frac{1}{4}$  volts and  $\frac{1}{4}$  ampere of current. These tubes will operate satisfactorily on a single dry cell, which eliminates the troublesome storage battery. The "B" battery, on the other hand, lasts for months; after which it is renewed.

Once we have attained the vacuum tube category of receiving sets, the only difference in the various offerings is in the matter of elaborateness. The tuning facilities, which means the ease and the preciseness with which the set can be adjusted for any given wave length, are an important consideration. In radio-phone reception it is highly desirable to

be able to tune in a desired radio-phone programme and tune out undesirable programmes. This gives not only choice, but also gives a clear and pure rendition of the desired programme. Otherwise, muddled sounds are heard as though several persons were talking at one time or several orchestras or bands were playing different selections all at one time.

Speaking of tuning, it is well to bear in mind that some of the present offerings are designed with the layman very much in mind. These receiving sets have a simple tuner arrangement, because it is realized that the user does not want to master the handling of a number of controls to be found on the more professional sets. If the purchaser is of an adaptable turn of mind, it may be well to look

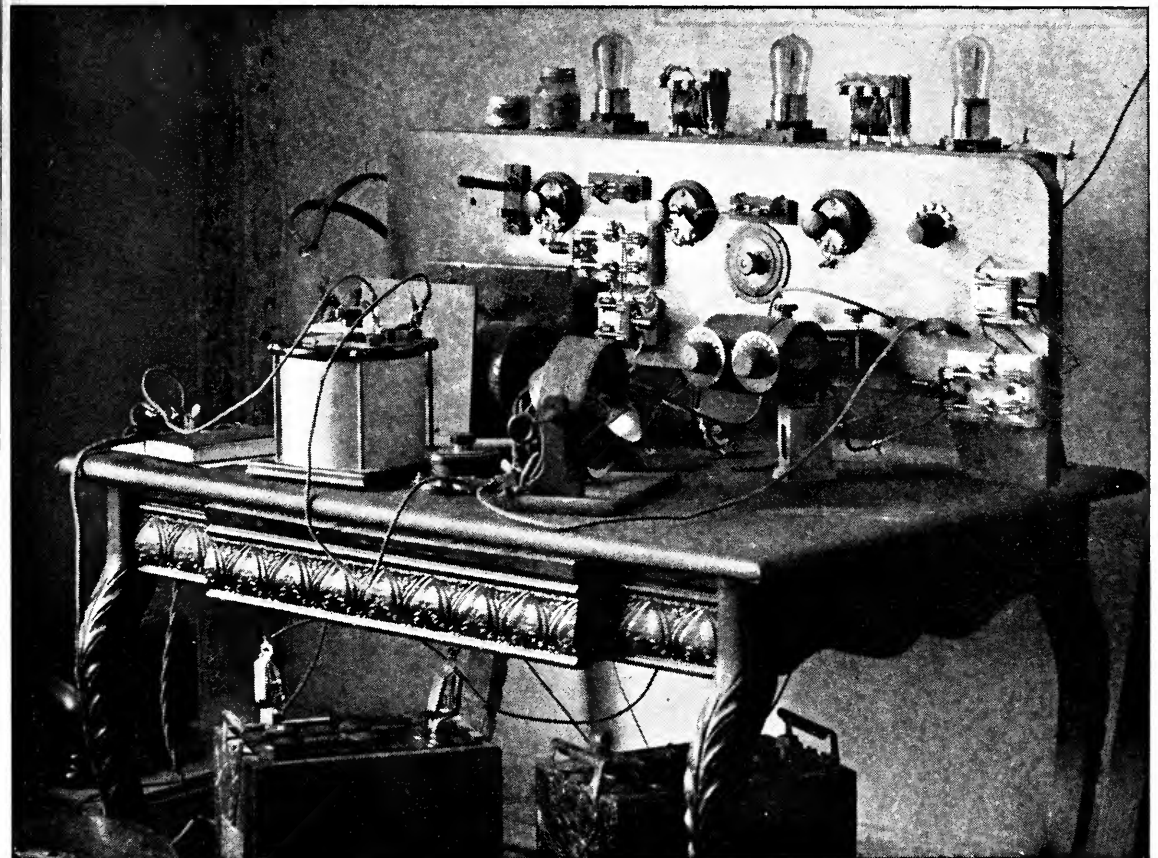

This Radio Regenerative Receiving Set, built by A. C. Philips, Hempstead, N. Y., has proved very effective. The antenna is composed of four strands of solid copper wire spaced two feet, eighty feet long, with a twenty-one foot lead-in. Height 51 feet. A home-made inductance wound on cardboard is used, with movable secondary, and taps on primary. A home-made variometer is used in the circuit as a tickler. The detector and two step amplification is made of standard parts. Double pole double throw switches connect to honey comb coils for long wave lengths. The following stations have been regularly and plainly heard. WJZ—WGI—WBZ—WGY—WWZ—KDKA—WDL—NOF—2XJ—IBKA—WYEB. The layout was arranged after a great deal of experimenting with different makes of standard parts, and left as shown owing to the fact that results were most satisfactory. Six sets of phones connected in series around the receiving room afford convenience and comfort to those who listen in.



into the sets with a number of tuning knobs, because good tuning does call for a number of tuning members. There is no such thing as simplicity combined with utmost efficiency in radio reception. Good tuning can only be obtained with a number of controls.

Another point to bear in mind is that the most important development in radio reception has been the introduction of the regenerative scheme invented by a radio engineer named E. H. Armstrong. To go into details concerning the Armstrong scheme is virtually impossible in this limited space, and a description of his invention was published in the last issue of RADIO BROADCAST; but suffice it to state that the Armstrong regenerative scheme simply converts part of the battery energy into oscillatory energy which is added to the incoming wave energy, giving greater strength to the ultimate sounds heard in the telephone receivers. Thus the detector is not only a detector but an amplifier as well.

So in purchasing a vacuum tube receiving set it is well to find out whether or not it is a regenerative set. Other vacuum tube sets will give good results, but the regenerative arrangement makes for greater range and louder signals with little more complication.

The simplest regenerative receiving set selling for \$75.00 will cover a distance of 75 to 100 miles under normal conditions, with a good antenna. For shorter distances it will give exceptionally loud signals, and will permit of using a number of pairs of telephone receivers. For distances above one hundred miles, it is necessary to use the more elaborate kinds of receiving sets of the regenerative design, together with what is known as the amplifier.

The amplifier may be included in a given receiving set, or it may be a separate piece of equipment. The amplifier increases the strength of the sounds heard in the telephone receivers, and thus brings up weak sounds, due to weak waves, to full audibility. It also makes possible the building up of weak sounds until they have attained sufficient volume to operate a loud-speaking horn, so that the music or speech can be thrown out in a large room and used for church, club, home entertainment or dance purposes.

Amplifiers come in the one-stage and two-stage models, and sometimes in the three-stage model, although the last-mentioned type becomes somewhat too complicated in its opera-

tion for the average amateur. The one-stage amplifier builds up the sounds to about four or five times their normal strength, while the second stage builds up this amplified energy four or five times more, or sixteen to twenty-five times the normal strength. Hence it will be noted that the amplifier not only gives louder sounds, but it also increases the range of the receiving set not a little by making what would hardly be audible sounds fully audible and even loud. So the amplifier is necessary when operating over a distance of more than 100 miles. For 200 miles or more a two-stage amplifier is absolutely necessary.

The usual type of amplifier is known as the audio-frequency type, because it handles the sounds or the currents of audible frequency which have come through from the detector of the receiving set. There is another type of amplifier known as the radio-frequency type, which is just coming into limited use. This type handles radio-frequency current, or current representing the radio wave energy, and builds up such current before passing it to the detector, which converts it into audio-frequency current. The radio-frequency amplifier, which comes in one-stage, two-stage, and even three-stage combinations, builds up the intercepted wave energy and not the sound strength. It makes for remarkable sensitiveness and for the covering of great distances, but it remains for the audio-frequency amplifier to give loud sounds. Often the two types of amplifier are included in one receiving outfit.

In cases where an antenna of the proper size cannot be used, then resort must be had to an improvised antenna. Anything will do to intercept radio waves at a reasonable distance. Thus a single piece of magnet wire, as insulated wire of small sizes is called, may be placed about a room behind a picture moulding. A piece of wire some forty feet long, concealed and out of the way, is sufficient to receive broadcasted programmes over a distance of 50 to 100 miles with a good receiving set with two-stage amplifier. The same set with a good antenna, however, would cover a distance of many hundred miles. Distance must be sacrificed with such improvisations.

It is only a matter of time when antennae will be done away with in most amateur radio reception, and the so-called loop will be employed. This consists of nothing more for-



midable than a number of turns of insulated wire wound on a wooden frame a few feet square. This frame takes the place of the usual antenna and the ground connection. Its two leads are brought to the antenna and the ground binding posts of the receiving set. The loop is used indoors, and must be so mounted that it can be turned about on its vertical axis. When the loop is facing end on toward the desired transmitting station, it receives the signals loudest. Indeed, the loop is the basis of the radio compass, which has proved such a boon to navigators, enabling them to take their bearings from shore stations. The loop is invaluable in radio-phone reception because aside from the sharp tuning qualities of the loop as compared with the usual antenna, it also enables an additional distinction to be made between the desired transmitter and the undesired transmitters by swinging the loop into the best position.

The best type of receiving set must be employed in connection with loop antennae. The crystal detector will not do. Unless a very short distance is to be covered, say twenty-five miles or less, a two-stage amplifier must be employed. For greater distances than seventy-five miles, a two-stage radio-frequency amplifier must be used to build up the intercepted wave energy, and a two-stage audio-frequency amplifier may be used in addition to build up the sound strength.

The efficiency of radio transmission varies from time to time. One evening a given receiving set will receive loud and clearly from a transmitter four hundred miles distant. Another evening, it will barely receive from a transmitter one hundred miles distant. Therefore, the effective range of a radio receiving set is always based on the distance which it will span under average conditions, and often this range is greatly exceeded for short periods.

## Broadcasting on Power Lines

**A** DEMONSTRATION was recently given by General George O. Squier, Chief Signal Officer, U. S. A., of the application of his "wired wireless" or "line radio" system for broadcasting which is bound to have a far reaching effect on the future development of the broadcasting art. General Squier has demonstrated experimentally in his laboratories that it is entirely feasible and practical to transmit high frequency current telephony over power lines, electric light circuits, and for it to be received at any point on the line. A single transmitter connected to the power lines at some suitable point may broadcast over a considerable area and may be received by a large number of people by connecting receivers at various points on the line, the connection being made by a suitable plug in any light socket.

The transmitters or receivers are of the usual types now employed for radio telephony and may be connected to the power line in various ways; the preferred arrangement used at present is shown in the following diagram. In this method of connection, the danger of short circuiting the mains is entirely avoided, the condensers between the mains acting as a

by-pass for the high frequency currents only, permitting the power current, direct or alternating, but of low frequency, to flow along the

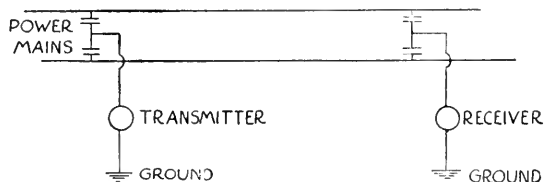

mains. For the radio currents the two mains are connected in parallel and used as one conductor, the ground being the return conductor. Good results are also obtained by connecting the transmitters and receivers between the mains, suitably protected by condensers to keep the large power current from passing through the radio apparatus, but the arrangement indicated above is more suitable.

The advantages of the line radio method of broadcasting as contrasted with space radio broadcasting are many. In the first place, the ether channels used for space radio broadcasting are limited, and even the few wave channels which are available for broadcasting can be more profitably employed for such radio activities where space radio is the only or best

method of communication. Also since there is no radio interference caused by broadcasting on power lines, any number of wave channels may be employed and therefore multiplying the number of stations that can be operated on the same line. It is conceivable that in every community we may have several transmitting stations operating at the same time, but each on a different wave length and supplying different services; one might be used exclusively for music, another for current news, and still another for educational information, etc. Also

by this means of broadcasting no antennae are required. A suitable plug connection in the light socket is all that will be required so that wherever the light circuits extend, which is nearly universal these days, radio broadcasting may be received.

It is hard to realize at this moment the vast possibilities of this method of broadcasting, but judging from the universal interest in the preliminary announcement in the press, it is a fair guess that the system will come into general use very quickly.

## Wire Broadcasting

By JOHN F. DUNCAN

This article supplements the preceding one entitled "Broadcasting on Power Lines" by expanding still further the speculative possibilities suggested.—THE EDITOR.

WHEN a pleasant spring evening comes and you walk down to the public square to hear the first band concert of the season, probably you'll never think of broadcasting until the racket of some small boys makes you say under your breath, "Just like that — spark station when I'm trying for KDKA." And then you suddenly realize that you are listening to broadcasting of the oldest known form—one which has existed since man first knew how to make intelligible sounds.

For centuries sound waves in the air were the only means by which we could reach the ears of other people. Our message could be either person-to-person, or broadcasted to an audience, as we might choose. Then came the telephone, and one person could communicate with another, or with a selected few, even though they might be thousands of miles apart. Although the energies of telephone engineers were directed primarily toward *individual* communication, there have been several successful attempts at broadcasting by means of wire circuits. Two of these are interesting because they foreshadowed many of the radio developments of recent years.

In Budapest a system was operated successfully for several years prior to the war, the subscribers of which could listen in at any time

and hear a programme more or less appropriate to the time of day. Thus, current news would be "on tap" in the morning; market reports during the day; society news in the late afternoon; entertainment programmes in the evening. This service was furnished over copper wires tapped off for each subscriber's listening set, much like the long "party lines" in country districts. The expense was met by a monthly charge to each subscriber, and presumably the venture was profitable.

In Wilmington, Delaware, the local telephone company about twelve years ago operated a "music" exchange, to which a telephone subscriber could be switched on request. Here were a number of phonographs equipped with telephone transmitters. The subscribers would give the title of the piece he wanted, and an operator would put on the record and start the machine. A charge for each record was made. If the person had no preference for a particular record, he was put on a "general" circuit which had a varied programme. A loud-speaking receiver with a horn could be rented for use at home, and a number were installed on a "pay station" basis at ice-cream parlors, restaurants, etc. For a time the system paid well, but eventually the general use of phonographs killed its market, and it was abandoned.

With the addition of radio broadcasting we have examples of the three possible ways by

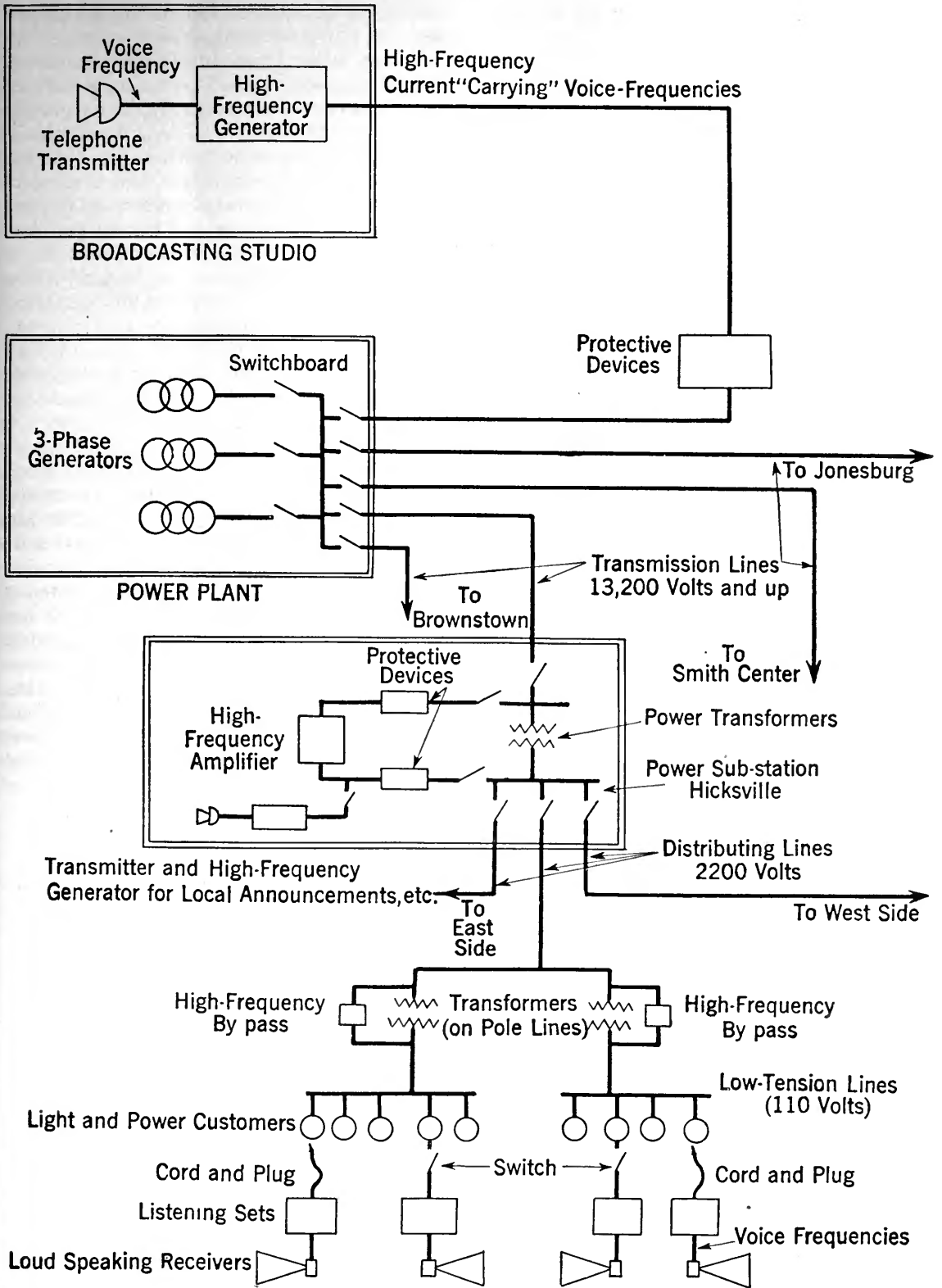

Fig. 1. Diagram of Carrier Broadcasting Set-up.

which voice or music can reach the ears of a large audience—by sound waves in the air, by electric currents on wires, and by radio. Each of these methods has its advantages and its defects, most of which are evident at first glance. Everybody knows, for example, that after the initial investment, a radio receiver costs little to operate, but its results are far from dependable at certain seasons, due to atmospheric conditions. The problem of paying for programmes sent out by radio is still unsolved. As broadcasting ceases to be a novelty, the publicity secured by an entertainer or lecturer through giving a "broadcast" performance will disappear, and these people will properly insist on payment for their services. But by whom?

If broadcasting is to become a permanent feature of our life, it is worth while to consider the real obstacles to its development, and examine wire broadcasting as a possible substitute for radio. The fact that the former system is limited to those persons who are "wired up" to it has certain decided advantages to its financial backers, and, paradoxical as it may seem, to its users. For a definite group of subscribers at so much a month is in a position to demand the sort of programmes it wants, and to insist on high-grade "transmission," free from noises and interruptions. The management of such a service is in the position of a theatre which will make money in direct proportion to its success in pleasing its patrons.

Such a sound economic foundation is indispensable for any permanent service.

It can safely be assumed that the cost of maintaining special wires to connect subscribers with broadcasting stations would be prohibitive—to say nothing of the difficulty of placing the wires in congested districts. This fact has been a stone wall which has blocked all attempts to develop this branch of the art. However, this particular wall has a gate whose key has been discovered within the last five or six years. Perhaps the analogy would be more accurate if we said that a ladder has been found by which we could climb up to a window and climb down again on the other side of the wall.

The gate or the window, as you prefer, is the use of existing wire plants, either of the electric light or telephone systems. There is nothing new in this idea; it occurred to many people years ago, yet the window was just out of reach. For instance, it was found that if telephone currents were passed through an electric arc, the original sound would be reproduced audibly, just as the old-fashioned alternating-current arc-lights would "hum" at the pitch of the circuit which supplied them. Some one proposed that a telephone transmitter should be connected to a city's arc-lighting system to broadcast police calls, news of robberies, etc. The difficulty, however, was that the arc-light was not a sufficiently "loud-speaking" receiver to be heard above street traffic, so nothing ever came of the idea.

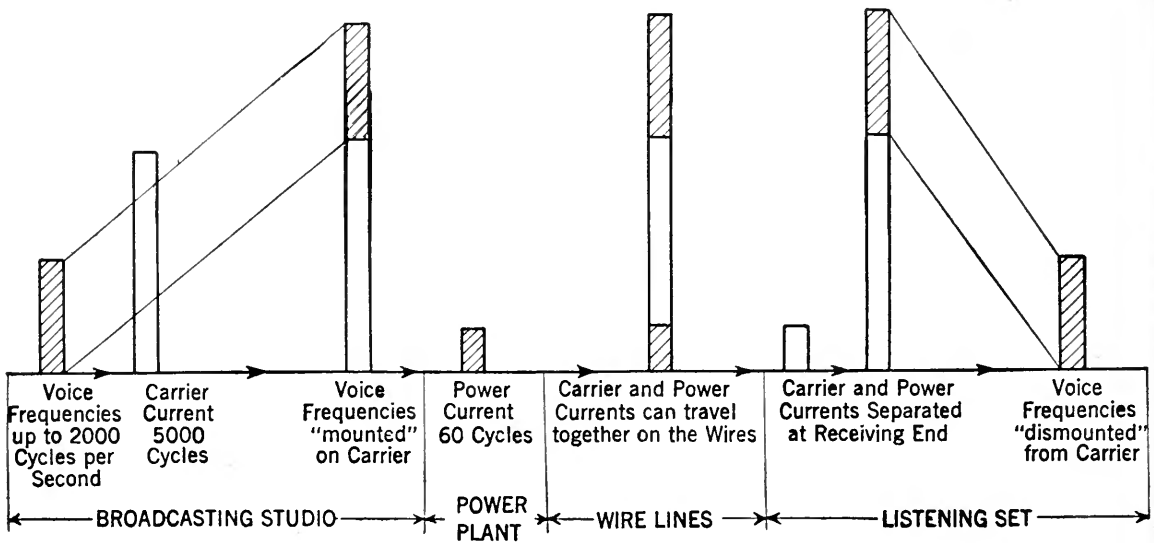

Fig. 2. How use of high and low frequencies allows wires to carry power and broadcasting at the same time

The principal difficulty in the use of electric and telephone wire lines is not in getting the "voice current" on to the wires but in getting it off. For electric light is usually alternating current, which at any commercial frequency is plainly and unpleasantly audible. And the telephone lines are built for the purpose of individual communication, which cannot be interfered with by "broadcasting." The problem of putting on another stream of "talk" without interference was only solved when a reliable method was found for using a high-frequency electric current as a "carrier."

This is where our analogy of the ladder comes in. The carrier in effect "lifts" the pitch of the intruding talk-stream to a point where it is inaudible, so that it does not interfere with the original use of the wires. At the receiving point it is then possible to separate the high-pitch (new) current from the low-pitch (original) current, and bring the high-pitch current down to its original (audible) pitch which may be heard in a telephone receiver or loud-speaker.

This explains in a rough manner what lies behind recent proposals to use electric light wires for broadcasting. We might have a central broadcasting station at the centre of a great power system, sending out its programmes over high-tension transmission lines to relay stations in each community. Here the "talk-stream" would be transferred to the distributing network reaching every house. Then by connecting a simple receiving set to any lamp-socket or wall-plug, we could "listen in" to news and music sent out hundreds of miles away.

Such a service offers attractive possibilities to electric service companies. Suppose such a company operates a system having one or more power plants connected with substations by high-tension lines. A broadcasting studio is built at any convenient central point and connected to the high-tension network through suitable protective devices. This studio might send out three or more programmes simultaneously—news and advertisements, popular and dance music, classical music, etc. Each of these programmes is carried by a different frequency, say 5000 cycles apart. By amplifiers at the substations, the losses in the transmission lines are made good, and the high frequencies transferred to the networks of distributing lines in each town. Where desired, a local programme can be sent out to the customers of a single substation. The apparatus used by the customers can be as simple to adjust as one of

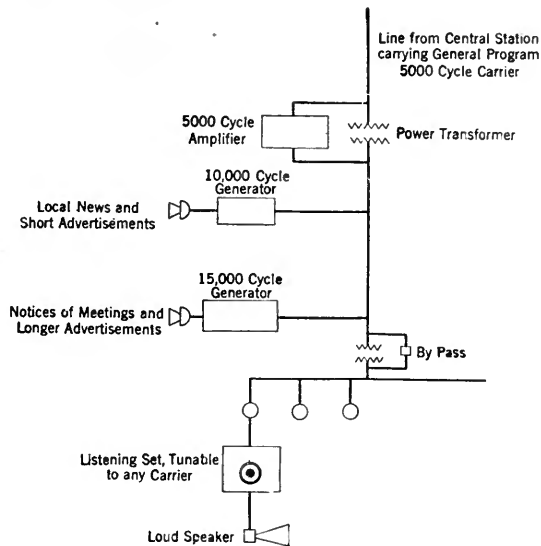

Fig. 3. Showing how three carriers can be used to give three programmes simultaneously

the radio sets now on the market which sells for \$65. Loud-speaking receivers can be supplied at varying rentals according to size, allowing their use in public places, such as hotels, restaurants, etc.

So much for the technical side of wire broadcasting. Commercially it offers several advantages to its users. The service would be furnished by a central organization fully responsible for the provision and upkeep of apparatus, just as are the telephone companies now. Users would have very little adjusting to do, and skilled assistance would always be available. With no static or fading to worry about, an evening's entertainment could be depended on at any season of the year.

All these advantages tend toward making broadcast receiving an exact science, instead of an art. To-day, skill and ingenuity count for a great deal. One reason why Jones builds a set is that his friend Smith has built one, and Jones isn't going to let Smith get ahead of him. Too, there is a powerful appeal to the imagination in tuning up a radio set and picking up stations all over the country. Perhaps it is the spirit of adventure that takes us on these journeys through the ether, rather than the absorbing interest of a lecture on ink or the charm of a church soprano's voice. If a large enough section of the public is interested in results, rather than in technical operation, then wire broadcasting offers a far better field for development than radio.

# Care and Operation of a Crystal Receiving Set

By EDGAR H. FELIX, A. I. R. E.

**A** RADIO receiving set is an instrument to which alternating currents from an antenna system are supplied, and which converts these alternating currents into sound waves.

The chief advantage of a crystal receiving set over other types is the small investment involved and the fact that there is no up-keep cost after the initial investment has been made. The chief disadvantages are the comparatively short range, lack of selectivity and instability of crystal detectors.

A crystal receiving set, however, if it receives at all, receives perfect music without any distortion of sound quality. In this respect it is superior to a phonograph. The output of a crystal detector, however, cannot be amplified by vacuum tube amplifier, and, for this reason, head receivers are always necessary when using a crystal set.

To operate any mechanical device successfully we must not only know what the controls are, but also what they do, how they do it and why. For instance, you could start an automobile if you were told to depress a certain foot pedal and pull a certain lever toward you, and then release the depressed foot control. But you would certainly be a failure as a driver if you did not know the function of the clutch and the purpose of the transmission. For this reason, in describing to you the best way to operate a crystal receiving set, I shall tell you the function as well as the effect of each control.

A crystal receiving set performs three functions: first, it tunes the antenna system to resonance with incoming ether waves; second, it rectifies the incoming oscillating energy so that it can be converted to sound; third, it converts the rectified oscillations into sound waves by means of head telephone receivers. Each of these functions will be taken up in succession.

Resonance is a familiar term to you, but it is hard to understand its application in

radio without the recourse to analogies. If a tuning fork of a certain period of vibration is set into vibration it starts a series of sound waves. If a second tuning fork of the same period is held near the first, it is set into vibration by the sound waves sent out by the first tuning fork. When two vibratory systems of any type have the same period of vibration they are said to be in resonance. In the case of the tuning forks the period of vibration is determined by the material and dimensions of the tuning forks.

The period of vibration or frequency of an electrical circuit is determined by its inductance and its capacity.

Whenever there is a change in the quantity or direction of current flowing through a wire, a magnetic field is set up. On the other hand, a change in the strength of a magnetic field always causes an electric current to flow through any electrical circuit within its influence.

If current is passed through a length of wire, the magnetic field built up induces a current in the opposite direction from that which caused the magnetic field. In other words a magnetic field builds up a current opposing that which caused it. In this way magnetism in electricity corresponds exactly to inertia in mechanics.

If, instead of a straight piece of wire, a given length of wire is wound in the form of a cylindrical coil, the magnetic field of one turn unites with that of the next and so on, greatly intensifying the magnetic effect. The coil in this form is called a tuning coil.

The inductance of any electrical circuit or instrument is a measure of the facility with which magnetic fields are built up. A cylindrical coil, for instance, possesses considerably greater inductance than a straight piece of wire of the same length as that used upon the coil.

The greater the inductance of a circuit the longer the time required for the magnetic fields to build up and to get up the opposing





This is a new General Electric crystal receiving set complete with telephone receivers now being featured by the Radio Corporation of America. This little receiver has a wave length range of 180 to 700 meters, made in two steps 180 to 400 and 300 to 700 meters respectively, and tuning is accomplished by a single control to which a pointer is attached which moves over a graduated scale. When the set is not in use, the receivers may be placed inside the metal case by removing the front

current. Consequently, an alternating current of very high frequency cannot pass through a circuit possessing a very large inductive value, but it passes through a circuit of small inductive value with great ease. For, possessing a correct value of inductance to pass the high frequency current, each time the magnetic field has built up and the reverse current starts to flow, the high frequency current is itself reversing. The use of the correct inductive values thus aids the flow of an alternating current while too much inductive value greatly impedes or stops the current.

The meaning of the word capacity is ability to hold. The capacity of an electrical instrument or circuit is its ability to hold electrons. Free electrons held in suspense by any force are termed an electric charge. A device especially constructed to hold a charge is called a condenser. When a condenser is designed so that its capacity may be continuously varied over a wide scale, it is called a variable condenser.

The diagram shows an inductance and capacity connected in series. If we charge this capacity by means of a battery let us see what happens. There is a positive charge on one set of the condenser plates and a negative charge on the other. These opposite charges are connected by a good conducting circuit through the inductance. Consequently there is a flow of electrons through the inductance until the two charges are equalized.

In passing through the inductance, a magnetic field was built up which in turn caused a current to flow in the opposite direction. As a result the charges on the condenser plates are reversed; the plate that was first positive is now negative and vice versa. These charges again neutralize through the inductance. If there were no resistance or losses in the circuit, we would in this way have perpetual charges and reversals of charges. Such a circuit is called an oscillatory circuit, and the current flowing in it an oscillating current.

The larger the inductance the longer time it takes the magnetic field to build up, hence the slower the period of vibration of the circuit. The larger the capacity, the greater amount of current required to produce a charge of appreciable strength which will cause a current to flow through the inductance. So the larger the capacity of the circuit, the slower the period of vibration.

In radio reception wave lengths between 100 meters and 25,000 meters are used. A wave length of 100 meters consists of three million vibrations per second; one of 25,000 consists of 12,000 vibrations per second.

When receiving signals from the ether, the aerial and the ground form the two condenser

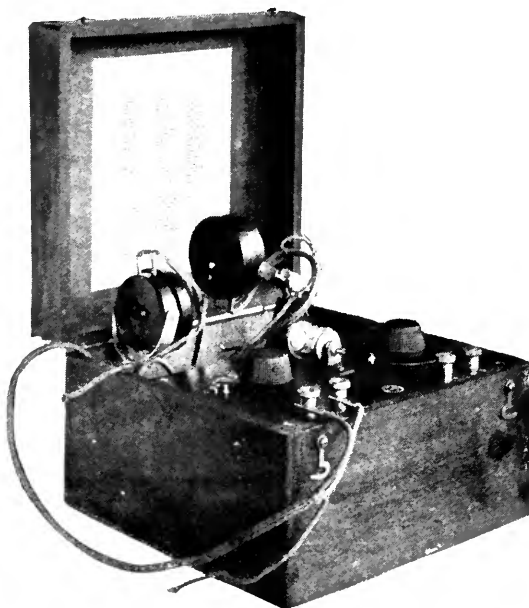

This is a complete crystal receiving set with two wave length controls, one of which acts as a fine adjustment on the other. This receiver is very useful for broadcasting reception. It may also be used to cover wave lengths up to 2,500 meters. It is marketed with a pair of sensitive telephone receivers

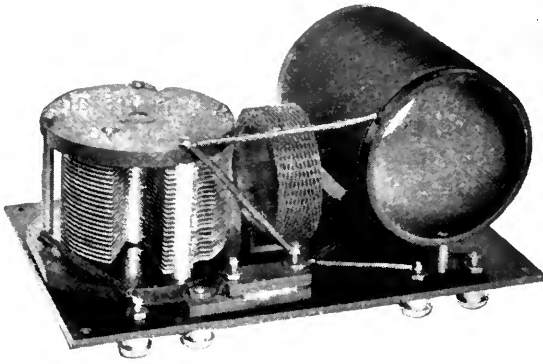

This is the interior of the crystal receiver previously described, and, as may be seen, the entire tuning equipment is mounted on a single Bakelite panel. A variable condenser is supplied for fine tuning and a lattice wound coil is used where wave lengths up to 2,500 meters are desired. This feature permits the reception of signals from the United States Government station at Arlington (Radio Va.)

plates of an oscillatory circuit. The inductance is the tuning coil or variometer used to vary the natural frequency of this circuit.

The first step in the operation of your set after your crystal is properly adjusted, consists of varying the inductance in the antenna circuit so that a current of the frequency set



This is the Aeriola Jr. Crystal Receiving Set manufactured by the Westinghouse Electric Manufacturing Company. Many of these sets have been sold on the strength of the company's broadcasting station WJZ at Newark, N. J., and these are used as receiving sets at that station. They are suitable for receiving waves of from 150 to 500 meters, and have an ordinary radius of 25 to 30 miles. They are sold completely equipped, except for the antenna. The cut in the next column shows the interior of this receiving set

up in your antenna by the transmitting station which you wish to hear, passes through the antenna system with the utmost ease.

The inductive value of the antenna system is in some receiving sets varied by means of a switch which cuts in or out small sections of a tuning inductance. Other sets use a variometer which is a special form of inductance so constructed that one half of the inductance opposes the other at minimum adjustment, and at maximum adjustment the two halves assist each other. In some sets the period of vibration of the antenna circuit is controlled by a variable capacity supplementary to the capacity of the antenna itself.

Now that we have our antenna circuit in

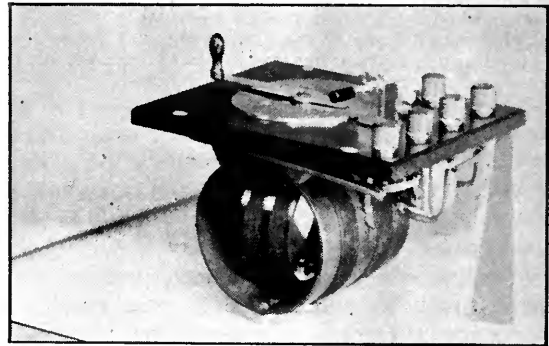

exact resonance with the transmitting station by proper adjustment of inductance and capacity, we must utilize the energy flowing in this circuit in order that it may be converted into sound waves. For this purpose a secondary circuit is used which obtains its energy from the antenna circuit. This secondary circuit should be in resonance with the antenna or primary circuit. When a two slide tuning coil is used, one slider varies the antenna wave length and the other the wave length of the secondary circuit. In such a set the same wire is used for both circuits and for this reason is called a direct coupled set.

Other types of receivers use separate windings for the antenna circuit and the secondary circuit. An instrument especially designed for this purpose, permitting adjustment of the distance between the primary and secondary circuit, is called a receiving transformer. The energy from the antenna circuit is transferred to the secondary by utilizing the magnetic field I have already described to you. The magnetic energy set up in the antenna inductance not only sets up a countercurrent in its own

circuit but also sets up a current in the secondary circuit which is within the magnetic field of the primary circuit.

The advantage of using two separate inductances for the primary and secondary circuits is that their physical relation or coupling may be adjusted. The looser the coupling—that is the further apart the two coils are held—the sharper and more exact the tuning of the two circuits. With a loose coupled set it is

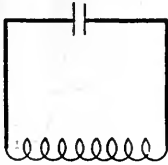

Fig. 1. An oscillatory circuit

usually possible to eliminate interference, which cannot be avoided with the single circuit set.

The tuning of an inductively coupled set is as follows: The coupling is first set at maximum; that is the primary and secondary inductances are placed in as close relation as possible. The antenna circuit is first tuned to the incoming wave; the secondary circuit is then adjusted to resonance.

Since the antenna circuit has the large capacity of the aerial and the inductive effects of the long wires, it usually requires comparatively few turns or little inductive value in the antenna circuit to place it in resonance with a much larger number of turns on the secondary inductance. A typical adjustment, for instance, is ten turns of antenna inductance to fifty turns of secondary inductance. Exact values cannot be given as this is determined by the size of your antenna, the length of the lead-in, the diameter of the coils used, and other conditions which are not standard.

Some sets are being manufactured which have but one control for wave length. In such sets close resonance is not always possible and for this reason they are not as selective as inductively coupled sets.

The result of placing the secondary circuit in resonance with the primary circuit through which a received signal is coming in is to have the secondary condenser charged and discharged millions of times per second. For instance, if you are listening to a 300 meter wave this condenser charges and discharges

one million times per second. This high rate cannot be converted into sound waves because no mechanical device can move so rapidly, nor would the ear respond to air waves of such rapid frequency. For this reason we use a crystal rectifier. A crystal rectifier allows current to flow through it in only one direction.

The function of the crystal detector, which is placed in series with the secondary inductance and capacity, is to allow an appreciable charge to accumulate on the plates of the condenser. It permits the plates to become charged in one direction, but prevents the discharge or equalization of the charges. When radio music is being transmitted on a 300 meter wave it is projected through the ether in vibrations of one million frequency. The voice or music is imposed upon this rapidly oscillating vibrating wave by means of modulation. Speech consists of intricate combinations of frequencies, ranging from 40 to 5,000 cycles per second. Modulation consists of changing the average intensity of the high frequency ether waves in accordance with the voice variations. Striking a second C above the middle C on the piano produces an air wave of 500 frequency. When this is sent over the radio telephone at 300 meters, modulation divides the one million frequency radio current into groups of 20,000 per second.

The crystal detector allows a charge to accumulate on the plates of the condenser. The modulation employed by the transmitter varies the amount of this average charge at voice frequencies. Head telephone receivers are connected across the condenser. The low frequency variations of the average charge pass through the telephones causing the diaphragms to vibrate. This in turn causes air waves which you hear.

Crystal detectors are of various types, but the process of adjustment in all cases is

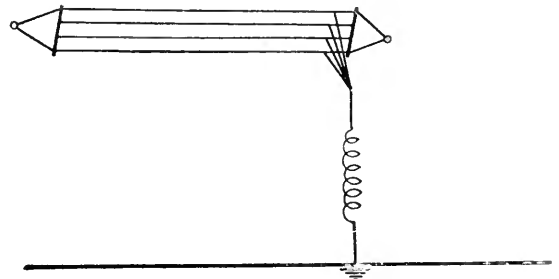

Fig. 2. The antenna circuit as an oscillatory circuit

approximately the same. Crystals are not sensitive at all points. The pressure of the contact on the crystal has an important bearing on its behavior. Sensitive points can only

this way the most sensitive spot may be found without waiting for signals to come in.

The sensitive mineral should be protected from dirt and grease. An enclosed case is recommended.

All switch contacts should work smoothly and easily. They should occasionally be polished so that they do not become dull from corrosion. Sliders should make firm contact,

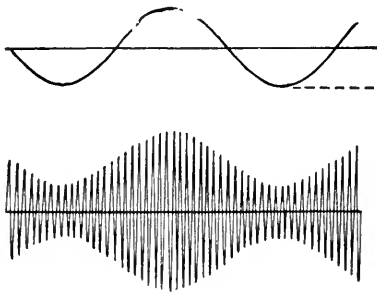

Fig. 3. Modulation of high frequency current. Upper curve represents voice wave; lower curve a high frequency current modulated by this voice current

be found by experiment, and the exact pressure to which the contact should be adjusted by experience.

A valuable aid in adjusting a crystal detector is the use of a test buzzer. A wire is connected from the terminal of the high pitched testing buzzer where contact is made with the vibrating arm. The tiny spark which you can see where the contact is made and broken serves to identify the correct terminal. This contact is connected with the secondary tuning inductance and causes a signal of standard strength to flow through the secondary circuit whenever the buzzer is put in operation. In

yet not too firm to wear out the wire on the inductance.

The care and operation of a crystal set is a simple matter and brings its just reward.

The pleasure you obtain from a crystal receiver hinges largely upon your skill in adjusting the crystal detector. Transoceanic signals have been received on crystal sets, but it is more to the credit of the skill and patience of the operator than to the efficiency of the crystal receiver.

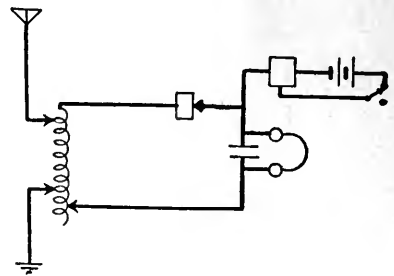
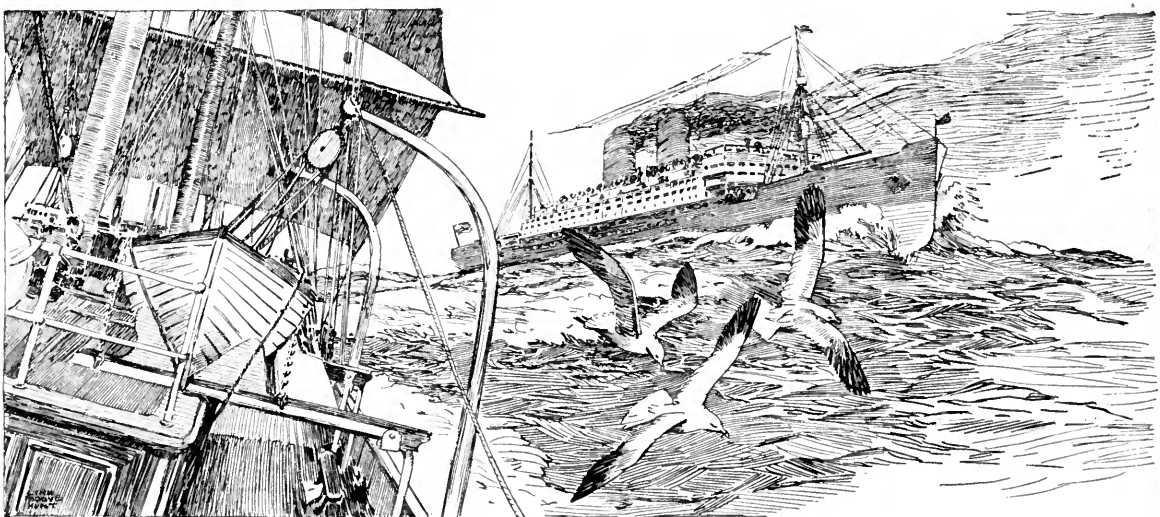

Fig. 4. Crystal receiver circuit showing test buzzer connections



# Keeping the Stars and Stripes in the Ether

By COMMANDER STANFORD C. HOOPER, U. S. N.

Head of the Radio Division in the Bureau of Engineering, Navy Department

IT CAN be stated without fear of contradiction that the very real importance of wireless, or radio, to the civilized world, and its almost limitless possibilities were not generally recognized prior to the outbreak of the war in Europe in August, 1914, except possibly by the military and naval officials of the leading powers who were intimately familiar with this branch of science, and by a few of the commercial concerns of the leading industrial nations engaged in world trade.

Any doubts which may have been entertained in the public mind of the practical utility of radio, must have been dispelled shortly after the outbreak of the war. These possible doubts were probably more quickly dispelled in Germany than elsewhere, because that country and its Allies were promptly isolated, so far as the exchanging of rapid communications with the North and South American Continents, Asia, Africa and the greater part of Europe was concerned, by the prompt cutting of all of her trans-ocean cables and the severing of other channels for exchanging rapid communications, except through her radio stations.

Upon the outbreak of the war in Europe, Germany was one of the two leading powers of Europe and one of the three leading powers of the world as regards the development and application of radio as a medium for exchanging rapid communications over both short and long distances, the other European power being Great Britain and the third power, although by no means third in rate of progress, being the United States of America.

The German Empire had already penetrated the United States in a radio sense by the establishment, in the year 1912, of the high power radio station located at Sayville, Long Island, New York, and a German firm was actively engaged in the construction of a second high power station at Tuckerton, New Jersey, when the war broke out, the latter named station ostensibly being established for a French concern.

An enormous volume of traffic, considering the limited normal traffic capacity of the station, was exchanged, subsequent to the outbreak of hostilities in Europe, between the Sayville station and a corresponding station situated at Nauen in Germany. In fact, this Sayville-Nauen circuit afforded the Central Powers the only channel for exchanging rapid communications with the outside world subsequent to the cutting of the German cables and the severing of the other channels of communication by the Allied Powers.

The British Marconi Company, a strictly commercial concern, with which the British Government was frequently rumored to be at odds, had also indirectly entrenched itself in the United States for communication purposes, by the formation of its affiliated company, the Marconi Wireless Telegraph Company of America. A considerable portion of the stock of this company was held by British subjects, and, as a natural consequence, the directing heads of the organization also were influenced largely by British subjects.

The operation of the German radio stations in the United States after the outbreak of hostilities, proved to be very embarrassing to our government, as the question of the maintenance of neutrality on our part was directly involved. Eventually it was found necessary to supplant the established censorship of the radio traffic passing through these stations by the replacement of the administration and operating personnel by radio personnel of the United States Navy.

The exchange of traffic between high power stations of the Marconi Wireless Telegraph Company of America located in the United States and corresponding stations of the British Marconi Company was prohibited by the British Government as a war measure, adequate facilities being available to the Allied Powers for the exchange of rapid communications by means of the transatlantic cable systems.



OWEN D. YOUNG

© Underwood & Underwood

Chief Counsel and Vice President of the General Electric Company, whose sense of patriotic duty, totally regardless of financial considerations, was the determining factor in the successful conclusion of the negotiations with the Navy





REAR-ADMIRAL WILLIAM H. G. BULLARD, U. S. N.

Who, as Director of Naval Communications in the Navy Department, so ably presented the Navy's point of view at the conference with the officials of the General Electric Company

© Clinedinst

The prediction enunciated in the following paragraph of the Government's radio policy, as established by President Roosevelt in the year 1904, may therefore be said to have been fulfilled:

"Because international questions may arise, due to the fact that the use of wireless-telegraph stations in our own possessions may affect the use of similar stations in foreign countries, it is desirable for the Congress to enact legislation which will enable the Government properly to handle such cases; failure to do so may seriously embarrass the Government at some future time."

These incidents served to emphasize the urgent necessity on the part of our government more clearly to establish its radio policy and to enact suitable legislation to effectually cope with abnormal conditions.

Upon our entrance into the World War the Sayville and Tuckerton stations were seized by the Alien Enemy Property Custodian, their operation, of course, being continued in the Government service by the Navy.

All non-government owned radio stations were promptly taken over by the Government and their maintenance, operation, protection, and administration entrusted by Presidential Proclamation to the care of the Navy.

Immediate steps were taken to improve not only the ex-German Sayville and Tuckerton stations but also the American Marconi's high-power stations to make trans-ocean communications by radio really effective and reliable and to meet the greatly increased requirements for trans-ocean communication as a result of our entrance into the war, and to provide an emergency means of trans-ocean communication in the event of the cutting of the cables by submarines, a contingency which was by no means regarded as remote.

Subsequently the Navy entered into negotiations with the American Marconi Company and also the Federal Telegraph Company, and, as a result, the Government purchased all of the Marconi Company's coastal medium and low power stations which included those situated in Alaska. It also purchased similar stations of the Federal Telegraph Company in the United States and the Hawaiian Islands.

As a consequence the Government obtained ownership of practically all shore radio stations situated within American territory, with the

exception of the Marconi Company's high power trans-ocean stations located at New Brunswick, New Jersey, Marion, Mass., Bolinas, California, and Kahuke in the Hawaiian Islands, thereby making our position as regards radio in connection with the national defense more secure, regardless of possible future legislation, as well as eliminating duplication of stations and ameliorating the exasperating problem of interference.

The only remaining feature of the situation which did not conform to the long established radio policy of the Government, especially as regards possible future embarrassments with respect to our status as a sovereign state, was the remaining practical ownership and direction, by other than United States citizens, of the American Marconi's high power stations situated within the United States and in the Hawaiian Islands in the Pacific.

It was obviously impracticable for our government to operate high power radio stations for exchanging communications with commercial stations situated in foreign countries, as a business venture, although the operation of such stations situated within the United States and in our outlying possessions for serving our Atlantic, Pacific and Asiatic Fleets had always been and is now, regarded as essential for military reasons.

The only logical solution of the problem therefore was to encourage the formation of a strictly American radio commercial company to take over the Marconi high power stations situated within American territory.

Negotiations were undertaken therefore with this end in view, and, on April 7, 1920, the Radio Corporation of America, a 100 per cent. American concern, came into existence, this corporation taking over the entire interests of the former Marconi Company, and incidentally assuring to our country, in conjunction with the existing extensive Naval radio stations, supremacy of the "ether" or, in other words, supremacy in the wireless service of the world.

The supremacy of America in this respect will be appreciated when it is understood that it has required more than twenty years of patient study, investigation, experimentation, and trial to develop the radio art to its present stage where not only ordinary radio communications between ship and shore can be reliably carried on, but where trans-ocean communica-

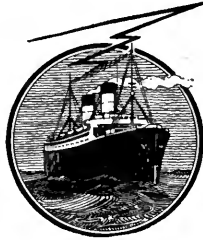

tions can also be reliably carried on in active competition with the ocean cable systems. When it is understood further that there are now ten super-high power radio stations in daily operation in the United States, five of the Radio Corporation of America, and five Naval, and seven similar stations in daily operation in our outlying possessions, one of the Radio Corporation of America, and six Naval, making a total of seventeen such American stations, one gets the picture. These stations are capable of spanning the Atlantic and Pacific Oceans, the Gulf of Mexico, the Caribbean Sea, the Gulf of Alaska, the Bering Sea, and reaching out into the Mediterranean, Black and Red Seas, the Indian Ocean and Asiatic waters.

The reliable effective transmitting ranges of each of these stations is from 3,500 to 6,000 miles, and, as the stations are located along our Atlantic and Pacific coasts, in the West Indies, in the Panama Canal Zone, in Hawaii, Guam, and the Philippines, it is obvious that their effective transmitting ranges cover the entire globe.

In addition to these, there are approximately 200 medium and low power stations having effective reliable communication ranges from 500 to 3,500 miles.

The number of American super-high power stations alone exceeds those of the rest of the world combined.

When the importance of radio is more fully realized by the general public, with the passing of time and the effecting of new developments in the radio art, the date of April 7, 1920, is likely to stand out more and more prominently in the history of radio signalling in its various forms and its relation to American interests and to the world.

Before that date, the birth-date of the Radio Corporation of America, there had been two or three attempts to form a large strictly American commercial radio company, but always without definite success. The Navy never had felt free to give full encouragement to the American Marconi Company because of its non-American character, as it was the established policy of the Government to encourage only companies controlled, at least largely, by American citizens.

The negotiations leading up to the formation of the Radio Corporation of America, and the decisions necessary to bring this about required

foresight and courage, and a high sense of patriotic duty on the part of those prominently engaged in its successful accomplishment.

The writer claims no credit for the result achieved, other than having made the original suggestion that the time seemed opportune to bring about its accomplishment.

After the negotiations were gotten under way the necessary details were handled by those within whose province those details came.

Special mention should be made however of the name of Admiral Bullard, who was detailed to the Department for duty as Director of Naval Communications and for carrying on the negotiations for the Navy; and particularly of the name of Mr. Owen D. Young, Chief Counsel and Vice President of the General Electric Company, whose sense of patriotic duty, totally regardless of financial considera-

tions, was the determining factor in the successful conclusion of the negotiations.

The United States had not long been in the war when it became evident that the trans-Atlantic and trans-Pacific cables were loaded to their full traffic capacity, and it became obvious therefore that preparations would have to be made to handle large volumes of trans-ocean traffic by radio, thereby not only augmenting the cable service but providing emergency communication facilities should the cables be cut by submarines, especially the trans-Atlantic cables, the safety of which was by no means certain.

As Head of the Radio Division, the responsibility devolved on me to formulate plans, as far as the material matters were concerned, and consequently I arranged for conferences early in the fall of 1917 to decide definitely on plans for building up this service.

Representatives of the Army and of the Allied Powers were present at these conferences.

The requirements were placed before the conferees, and, as a result of the deliberations, definite plans were made, and the service was eventually built up to such a state of perfection that trans-ocean communications were made reliable and effective throughout the year.

This necessitated the replacement of the German transmitting apparatus by more modern and powerful equipment of American manufacture in the Sayville and Tuckerton stations; the replacement of the Marconi apparatus in the New Brunswick station by

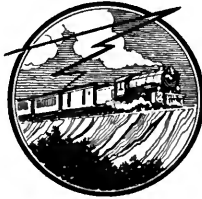

Alexanderson alternators of the General Electric Company's manufacture, and the establishment of a 500-kilowatt power transmitting station at Annapolis, Maryland, and a corresponding station, but of twice this power, or 1,000 kilowatts, at Croix d'Hins near Bordeaux in France. Poulsen-Federal arc transmitters of the Federal Telegraph Company's manufacture were installed in the last named two stations, these two stations being the most powerful radio stations projected in the world at that time.

The Navy was charged with the full responsibility for all matters pertaining to radio after our entrance into the war, with the exception of strictly Army communication matters, and very close coöperation was maintained with the Army, as evidenced by the fact that the Navy took full charge of the construction of the 1,000-kilowatt station in France to insure the maintenance of rapid communication facilities for our Expeditionary Forces in France in the event of the cutting of the cables.

The Navy therefore had available to it the combined radio engineering talent of the entire United States, and too much praise cannot be given to the civilian radio engineers for the services rendered the Navy in this emergency.

As a result of the abnormally rapid advance brought about in the development of the radio art, as a consequence of the exigencies of war, and with the consequent production of new and improved apparatus and the inauguration of improved methods, the General Electric Company was found, upon the cessation of hostilities, to possess the ownership of a large number of the valuable patents covering modern radio apparatus, such as the Alexanderson alternator or transmitter, the vacuum tube transmitting and receiving equipment and the photographic recorder for automatic reception of radio traffic at high speed of say 200 words per minute as distinguished from the normal average hand sending speed of 20 words per minute.

The British Marconi Company, having previously enjoyed possession of ownership of the most valuable radio patents, were tardy in their research work, as they apparently felt that they enjoyed a monopoly in this respect, and need have no fear of a competitor.

It was apparent however that they suddenly became convinced that if they did not get hold

of certain General Electric patents, either the patents themselves or the license right of them, they would be unable to compete long in modern radio, because it was obvious that a company having the improved apparatus covered by these patents could cut in on them seriously, and perhaps drive them out of the field.

Negotiations were entered into with the General Electric Company by the British Marconi Company following the war with a view to effecting the purchase of several million dollars' worth of the improved apparatus, information to this effect becoming available to the Navy Department through the ordinary trade channels.

When I heard of this impending deal, I became convinced that the whole future of American radio communications was involved, and it was my conviction that the Government's established radio policy would fail utterly if any deal was

made which would give the British Marconi Company the sole rights to these patents or would give them a chance to get the first out-put of this modern apparatus from the General Electric Company's factories, because if they acquired the apparatus and had time to place it in service, no other radio company could catch up with them, and it would be impossible to interest American business men in the establishment of a strictly American commercial radio company, owing to the tremendous power which the British Marconi Company would have acquired.

The situation appeared to require immediate action, and, obviously, some degree of secrecy was essential.

On April 3, 1919, Admiral Bullard had but three days before arrived in Washington and taken up his new duties as Director of Naval Communications in the Navy Department, but as yet had had no opportunity to familiarize himself with the situation when the writer, accompanied by Commander George C. Sweet, United States Navy, now retired, went to him and laid the whole situation before him, with recommendations that a conference be held with the directors of the General Electric Company.

As a result of this conference, it was decided at once to get into touch with the General Electric Company by long distance phone with a view to arranging a conference in which the entire matter could be laid before the directors of the Company from the Navy's point of view.

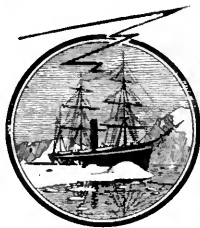

I communicated with the General Electric Company and requested that we be given an opportunity to meet the directors on very important matters at the earliest possible date.

As a result, a conference was arranged with the General Electric officials, this conference taking place at 120 Broadway, New York, on April 7, 1919.

Admiral Bullard very ably presented the Navy's point of view to the conference and impressed the officials of the General Electric Company with the seriousness of the situation from a national point of view. After extensive questioning by Mr. Young of the General Electric Company he became convinced that it would be unpatriotic for the Company to continue its plans with the British Marconi Company, and that there was nothing for it to do but to cancel the proposed agreement with the British Marconi Company, and it was due to his courageous decision and able presentation of the situation that Mr. Coffin, Mr. Rice, Mr. Stone and Mr. A. G. Davis and others of the directors present were convinced that drastic action was essential, regardless of financial considerations, on the part of the Company.

After giving thorough consideration to the subject, the General Electric Company's representatives made the statement that they had not previously realized the importance of the matter from a national point of view, as they were a manufacturing concern and in the market for world trade, but that decidedly, they had no intention of subscribing to any plan which would prove inimical to the best interests of the United States.

The Navy representatives suggested that the Company should go into the radio operating business itself, or make some arrangements with existing American companies to handle the radio situation in a way that would guarantee American interests not only from a business point of view but also in the interests of the national defense.

The plan agreed upon by the Company in the conference of April 7, 1919, was that, if the General Electric Company obtained the British holdings in the American Company, they would absorb the Marconi Wireless Telegraph Company of America.

It was subsequently ascertained, however, that the American directors of the American

Marconi Company were in a receptive frame of mind as regards coming into the new company, as they themselves were aware of the fact that the major portion of the stock of the company was in British hands, and they frankly stated that the previous arrangement had never been quite satisfactory to them, that it had been looked upon with some anxiety and that therefore they welcomed some new arrangement such as the one proposed.

As a consequence the General Electric Company arranged that Mr. A. G. Davis and Mr. E. J. Nally (representing the American interests of the American Marconi Company) should go abroad for the purpose of terminating the pending deal for new apparatus, and also to negotiate with the British Marconi Company's officials for the purchase of their interest in the American Company, it being subsequently verified by their representative that the British interests were very large indeed.

At this time we were still using the service that we had built up during the war and were doing a tremendous amount of business across the Atlantic and Pacific oceans, but we were very desirous of transferring other than the Navy stations back to private ownership as soon as the deal could be accomplished.

Finally the General Electric Company was successful with the British Marconi officials and satisfactory arrangements were also made with the American officials of the American Marconi Company, and as a result the Radio Corporation of America was established.

With a view to making it possible to market the vacuum tube receiving equipment, the General Electric Company and the American Telephone and Telegraph Company exchanged licenses on their equipment, and the Radio Corporation of America came in on this exchange. In other words, the American Telephone and Telegraph Company with its subsidiary the Western Electric Company, the General Electric Company and the Radio Corporation of America all cross-licensed with one another in order to facilitate the sale of the American controlled equipment, this arrangement being due partly to the suggestion of the Radio Division of the Navy.

This arrangement was distinctly in the best interests of the public service, because it provided for the production and application in





service of this most important apparatus which otherwise would have been greatly retarded owing to the badly tangled patent situation among the American radio concerns themselves, and it resulted in the American radio services being freed from the handicaps which would otherwise have greatly retarded the forward march of progress in the development of the radio art in the United States.

The Navy in other ways gave its best advice and coöperation to the newly formed Radio Corporation of America for reasons which are obvious from the foregoing.

The cross-licensing on the part of the American Telegraph and Telephone Company, General Electric Company and Radio Corporation of America, together with our extensive and efficient manufacturing facilities for radio apparatus, and our extensive and widely separated chain of shore radio stations, has placed the United States in an unassailable position as regards all matters pertaining to radio, the immense value of which from the point of view of our humanitarian efforts, the national defense, our commercial interests and the nation's prestige throughout the world will undoubtedly be more fully realized as time goes on and further developments are made in the radio art.

Subsequent to the arrangements having been mutually made between the above companies, the Westinghouse Manufacturing and Electric Company and the Tropical Radio Company were also taken into the agreement.

It may be stated that, as a direct result of

the conference of April 7, 1919, American radio became the most powerful in the world, whereas prior to that time the British Marconi Company must have felt that their hold on the world in this respect was secure. The really important feature, however, is that, as a result of that conference, all of the radio interests of the United States were for the first time placed entirely in the hands of American citizens.

The Navy pointed out to the newly formed Radio Corporation that it should be to their interest to have connections with South America, in order to extend the all-American chain of high power stations, in the interest of the advance of trade and coöperation between North and South America.

The British, Germans, and French had secured concessions in South America which made this situation a very difficult one to handle, but through able management a compromise was effected, and, as a result, the Radio Corporation has entered into an arrangement with the British, Germans, and French in South America, while yet keeping control of the advantages already gained as outlined in this article.

We are now entering upon the era of radio-telephony, the future developments in which and the results therefrom no one can foresee.

The possibilities for good or for evil are so tremendous that it obviously is of primary importance that we guard our pre-eminent position in the radio world and maintain the lead which we now enjoy.



## Radio Personalities

### III

#### R. A. HEISING

The Man Who Solved the Problem of Sound Modulation by Radio

By EDGAR H. FELIX, A. I. R. E.

**S**ELDOM does an inventor perfect his discovery and later realize its importance. The process is usually reversed and of four steps: first, the germ of an idea, second, a crude model; third, the acclamation of his discovery to the world; and fourth—if he ever reaches

that stage—the long and difficult process of perfecting the idea.

In this Reginald A. Heising, the inventor of the modulation system which makes broadcast music a practical possibility to-day, is the exception among a hundred great inventors. His discovery removed what had long been



the most baffling problem of radio telephonic communication. For some time prior to the development of the Heising system, methods of producing continuous waves, which are essential to radio telephone communication, were known to radio engineers. But the best of the pre-Heising modulation systems failed in controlling any but the lowest power.

"By what process," I asked Mr. Heising at his New York laboratories of the Western Electric Company, "were you led to discover your system of modulation?"

"During my college days I realized that radio telephony would never come to its own until we were able to control high powers of continuous wave energy by means of the voice. All efforts had been concentrated on perfecting the microphone so that it could handle high powers and heavy currents flowing through it.

"Instead of aiming to solve the weaknesses of the microphone, I sought other means. This naturally led me to make the experiments resulting in the system of constant potential modulation."

This phrase, "my college days," may lead the reader to think of Mr. Heising as an old man. He is not; he is young, of quiet mien and deliberate manner. My conversation with him convinced me that Mr. Heising's inventive genius lies in his ability to visualize his problem graphically. His conception of electric circuits is so clear that he mentally sees the minute currents throbbing through the circuits. As a result, instead of attempting to scale insurmountable obstacles he quickly perceives the weak point, through which he can attain his objective.

Immediately after obtaining his Master of Science degree at Wisconsin in 1914, Mr. Heising joined the research forces of the Western Electric Company. His success in dealing with problems in modulation resulted in the award, in 1921, of the Morris Liebmann Memorial Prize by the Institute of Radio Engineers. This is the highest tribute which the radio fraternity can bestow upon a fellow scientist.

When I learned that his first patent, which established the basic principle of the Heising system, was applied for within six weeks after he began his experimental work with the Western Electric Company, I asked:

"How were you able to solve in so short a time this tremendously important problem on



REGINALD A. HEISING

which experienced engineers had been working so many years before you were out of your teens?"

"I did not realize I was working on an important problem," answered Mr. Heising. "My first step was to get a concrete idea of what was needed and to consider the various ways in which it could be met. By imagining the various possibilities in operation, I was able to eliminate most of the possibilities which occurred to my mind. So I very soon concentrated my efforts upon the control of the space current of the generating tubes, instead of, as had been the practice in the past, attempting to control the current by varying the resistance of the antenna circuit.

"It required but a few laboratory experiments to prove the correctness of the principle, and patents were quickly obtained. Later experiments proved that constant plate potential, with variation of the current in accordance with speech was not as effective as control of the plate potential by the voice, with constant current."

"You say you did not realize the importance of the problem? Had you realized it, do you believe you would have been as quick in your success?"

"I do not mean that I did not realize the

importance of the problem. What was uppermost in my mind was the problem itself. In fact, it was not until the patents had been obtained, that I considered their significance. One night, shortly after patents were filed, as I lay awake, the possibilities of the system flashed through my mind. The technical and scientific improvement, I must admit, was quickly overshadowed by the whole vision of what the radio telephone could accomplish; its possible effect upon our national life and welfare and the social and economic value of the transmission of speech so that it could be heard all over the country at the same time. It has taken time to see the realization of some of these dreams and even to-day we are only making a beginning."

Briefly, the Heising modulation system is as follows: words or music actuate a microphone through which the current from a battery is flowing. The sound variations cause the resistance of the microphone to change as the sound waves impinge upon it. The current in the microphone circuit thus varies with the speech. Hence it is called speech current. The speech current, in turn, is impressed on the grid of a vacuum tube, causing similar but greatly augmented variations in the output of the tube. If high powers are to be controlled, this speech current is magnified by additional modulator tubes, until the voltage variation is sufficiently large to modulate the power output of the oscillator or radio frequency generating tubes.

The output of the last modulator tube is impressed upon the source of plate potential of the power tubes so that their source of plate potential rises and falls in accordance with the sound waves of the speech or music to be transmitted. The space current in a vacuum tube rises and falls with each change of plate potential. As a consequence, when the plate potential rises and falls in accordance with the sound waves impressed upon the transmitting microphone, the radiated energy varies in the same way.

Amateurs, who are interested in the principles of modulation or who wish to construct radio telephone transmitters, will find Mr. Heising's paper, "The Audion Oscillator," appearing in the April and May, 1920, issues of the Journal of the American Institute of Electrical Engineers, and the paper on "Modulation in Radio Telephony", in the August, 1921, issue of the Proceedings of the Institute of Radio Engineers of great assistance in designing their apparatus. In these papers, Mr. Heising describes fully all circuits used and the advantages and disadvantages of each.

Recently Mr. Heising conducted a series of experiments in operating a printing telegraph by radio. Their success proves radio to be as flexible as wire communication. As many as 29,000 characters have been transmitted through two channels working simultaneously in one hour, with but fourteen mistakes attributable to radio shortcomings. The speed with which the printer could be operated was in no way limited by radio.

The career of Reginald Heising is remarkable for the extraordinary directness with which he has solved the most perplexing problems—the result of his remarkable and almost intuitional perception of the essential facts in radio. The important invention which led to Mr. Heising's recognition as one of the foremost radio engineers and discoverers of our time—the solution of the problem of modulation—was made within six weeks after he was graduated from college and started to work. Since that time he has greatly improved his system until it has become an essential factor in radio telephony. The many patents which have been granted over Mr. Heising's name and his important contributions to scientific literature are evidences of continued progress. Being still a young man, it is natural that more great things are expected from him. In the meantime, broadcast enthusiasts have much to be grateful for to Mr. Heising.

# Here Are Four Well Known Radio Editors



Allen H. Wood, Jr., Technical Adviser on Radio to the Boston Sunday *Herald*

Jack Binns, Radio Editor of the New York *Tribune*

William F. B. McNeary, Radio Editor of The Newark, N. J. *Call*. Known to thousands of children as "The Man in the Moon"



Milton Waldeman, Radio Editor of the New York *Globe*

# What the Detroit "News" Has Done in Broadcasting

Being the Story of the First Local and National Election Returns, Music, World's Series Base Ball Results, Poetry, Theatrical Entertainments, Sermons and Speeches by Public Men Ever Broadcasted by a Newspaper

By R. J. McLAUHLIN

THE *Detroit News* was the first newspaper in the United States and, so far as is known, in the world, to perceive the possibilities of increasing its usefulness by furnishing the public with radio service. When the broadcasting was inaugurated nearly two years ago, wireless telephony, although it had reached a commercial stage and was already the hobby of a few enthusiastic experimenters, still remained a mystery to the community in general and was looked upon by many as possibly a familiar source of enjoyment to their grandchildren but of no particular interest or importance to the present generation. This

sentiment was changed virtually overnight when, in August, 1920, the *Detroit News* installed its first transmitting station and commenced its regular broadcasting.

The original apparatus consisted of a De Forest Type OT-TO transmitter, using a 200 meter wave length. Its range was limited, being, under the best of conditions, not more than 100 miles, and at this time there were approximately only 300 operators in the territory thus covered. The transmission set was in place ready for operation on Aug. 20, 1920, but no announcement was made to the public until a series of experimental concerts had been conducted over a period of ten days.

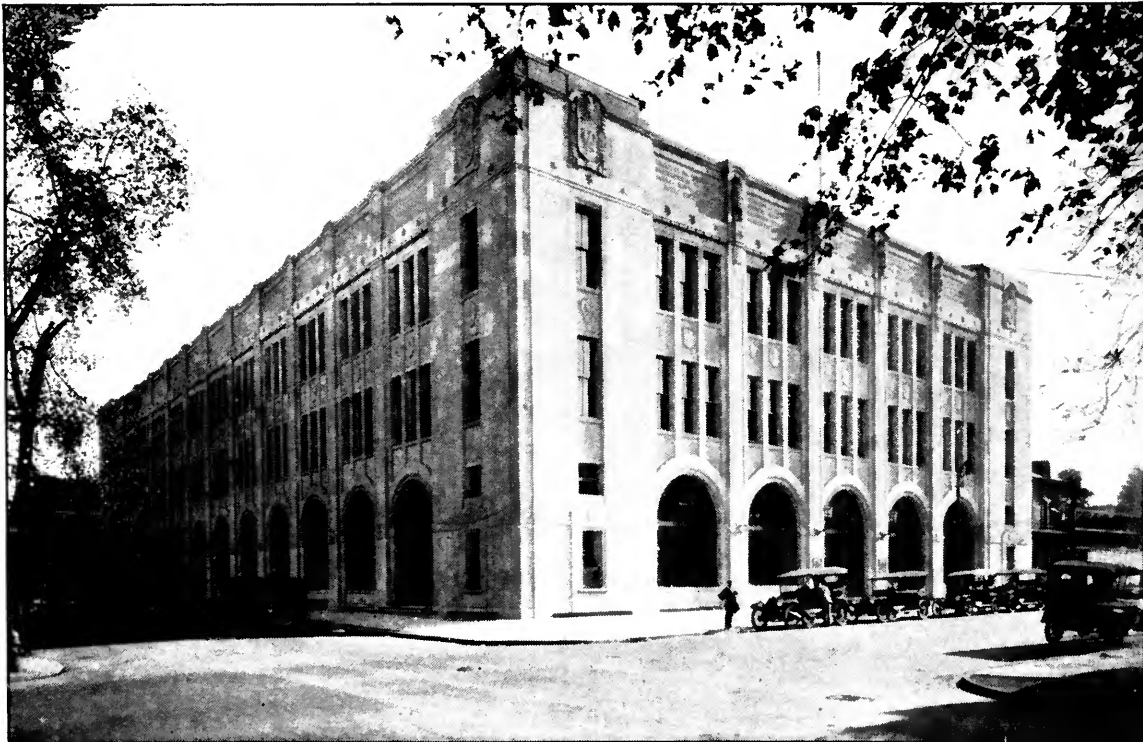

Detroit News Building

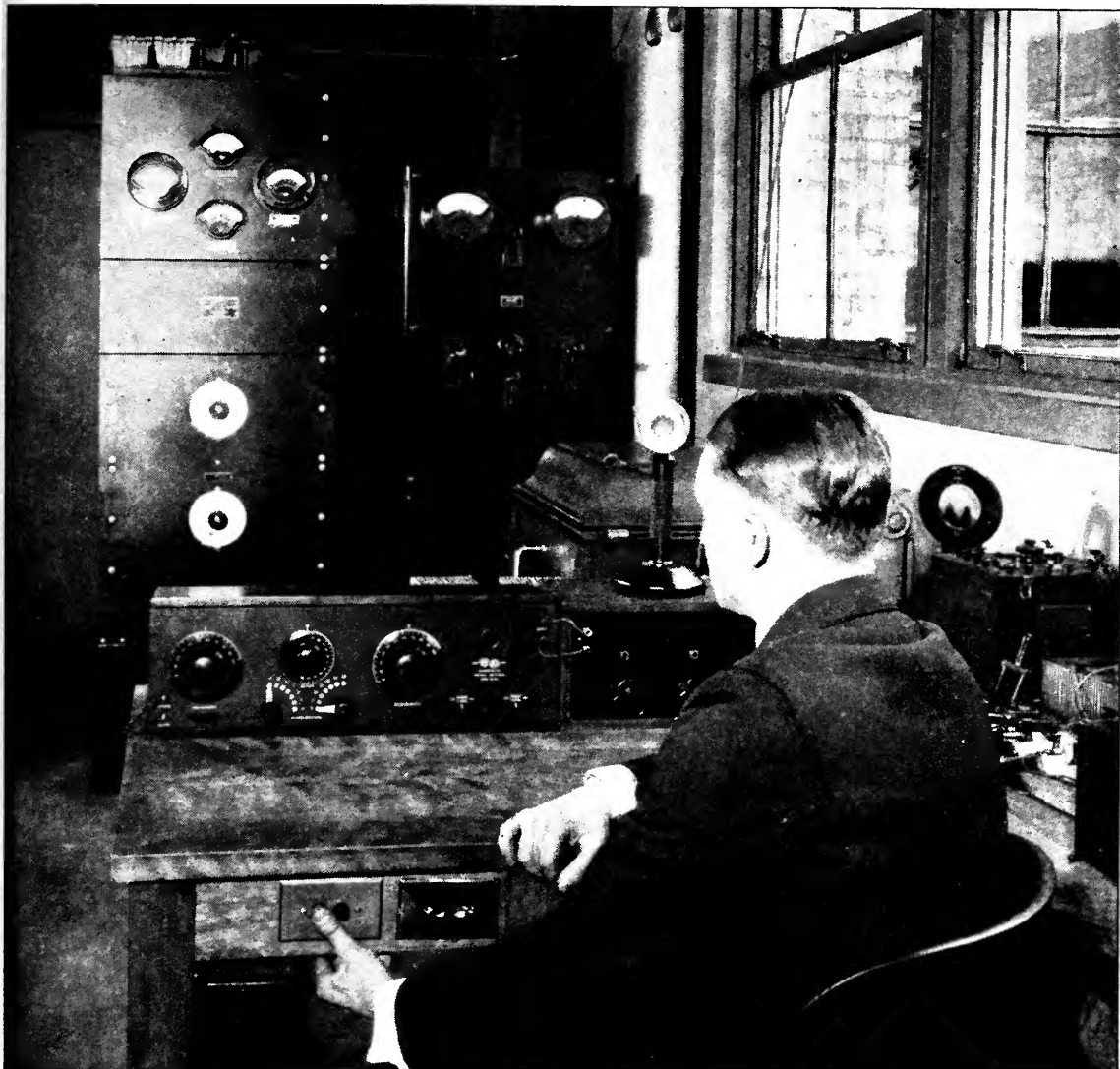

Chief Operator and part of Detroit *News* Radio Laboratory

These concerts were enjoyed by no one save such amateurs as happened to be listening in. Everything was found to be successful and satisfactory, and, on Aug. 31, which was the primary day, it was announced that returns from the local, state, and congressional primaries would be sent to the public by means of the radio.

The *News* of Sept. 1, carried the following announcement;

"The sending of the election returns by the Detroit *News* Radiophone Tuesday night was fraught with romance, and must go down in the history of man's conquest of the elements as a gigantic step in his progress. In the

four hours that the apparatus, set up in an out-of-the-way corner of the *News* building, was hissing and whirring its message into space, few realized that a dream and a prediction had come true. The news of the world was being given forth through this invisible trumpet to the waiting crowds in the unseen market place."

It was Aug. 31, then, which marked the beginning of wireless telephony as a social service. On that day the dream of actual vocal communication between points far distant and without any physical union came true on an astonishingly large scale. The public of Detroit and its environs was then made to



Robert W. Kelly, Radio Editor of the Detroit *News*

realize that what had been a laboratory curiosity had become a commonplace of everyday life, and that the future held extraordinary developments which would affect all society.

Every week-day since that date the *News* has broadcasted a programme to an ever-increasing audience. There has been no interruption in this service, and the programmes have constantly become more extensive and elaborate.

At first the concerts were confined entirely to phonograph music. Two programmes were broadcasted daily—one at 11:30 A. M. and the other at 7 P. M.—and, after a time, speakers and singers were occasionally secured to entertain the invisible audience.

Soon reports commenced coming in from outlying communities that the concerts were being successfully received and tremendously enjoyed. The radio has become such a familiar affair in so short a space of time that it seems odd to consider how remarkable this was regarded at the time. The thing held the

element of magic. The local receiving set became the centre of wondering interest in the little suburban town. The interest grew and dealers reported a demand for radio materials.

Then the steamer *W. A. Bradley* reported through the Marconi station at Ecorse—a little town west of Detroit—that the music of a *News* concert had been received where the vessel was steaming along through the night in the middle of Lake St. Clair. This, somehow, impressed the public as even more remarkable than sending the music over land, although, of course, it was not so. But the notion of a ship far off from land actually comprehending the words spoken and the music performed in a little room of a building in a great city seemed a peculiarly significant conquest over distance and darkness.

During the first week of broadcasting a party at the home of Mr. O. F. Hammond, 180 Parker Avenue, Detroit, danced to music sent out by the *News* apparatus and this was considered the local beginning of the social aspect of wireless telephony.

The man in the street, traditionally sceptical, was much impressed when, in October, 1920, the results of the World's Series contest between Cleveland and Brooklyn were instantly sent out to the waiting base-ball enthusiasts, and the first returns of a national election ever broadcasted were given by the *News* in November of the same year when hundreds of partisan voters held receivers to their ears and were informed by the voice through the ether that Harding had rolled up an enormous majority over Cox.

When the Christmas season came around, the number of radio amateurs had greatly increased in Detroit and the surrounding communities. Small boys were becoming great enthusiasts and Santa Claus remembered a great many with receiving sets. This added members to the *News* family of radio enthusiasts, and special holiday music, appropriate to the season, was broadcasted.

On New Year's Day of 1921 the *News* stated: "For the first time, as far as known, a human voice singing a New Year's melody of cheer went out across uncounted miles over the invisible ether that is the medium of the wireless telephone when Louis Colombo, Detroit attorney and famous baritone, sent his resonant tones into the mouthpiece at the office of the Detroit *News* at midnight, Friday."

And an astonishing achievement was con-



sidered to have been performed when those in attendance at a banquet at the Masonic Temple heard a concert received in the banquet hall by means of a three-wire aerial strung along the ceiling.

By this time the original transmitting set was found to be inadequate for the increasing requirements and it was almost entirely rebuilt. In the following June a two-wire antenna, 290 feet in length, was stretched between the *News* building and the Fort Shelby Hotel. Soon reports began to come in from distant points that the *News* concerts were being quite audibly received. Belleville, Ill., sent word that the concerts were enjoyed there and Atlanta, Ga., startled even the *News* operators by announcing that the broadcasting was carrying successfully to that distant place. Code messages came in from remote radio stations everywhere in the world, including the U. S. Navy station at Bordeaux, France, Nauen, Germany, and Hawaii.

The *News* now decided to organize its pro-

grammes on a more elaborate scale. They had previously been restricted, principally, to phonograph music and news bulletins, but now musicians were added and theatrical talent secured from Detroit playhouses to supplement this. The first noted literary man to send out his compositions through the ether to thousands of ear-pieces, was Edmund Vance Cook, the poet.

In December, 1921, the present ambitious programme was inaugurated. By this time the radio department occupied the entire time of a programme manager and two technical men, which staff has now grown to eight persons.

To-day phonograph music occupies an incidental place on the daily schedule, and the programmes are filled by stage celebrities, prominent clergymen, musicians and public figures of various sorts, many with national reputations. Among the noted stage persons who have made their radio debut in the *News* transmitting room are Frank Tinney, Van and Schenk, Percy Wenrich, and Lew Fields.



Detroit *News* Auditorium

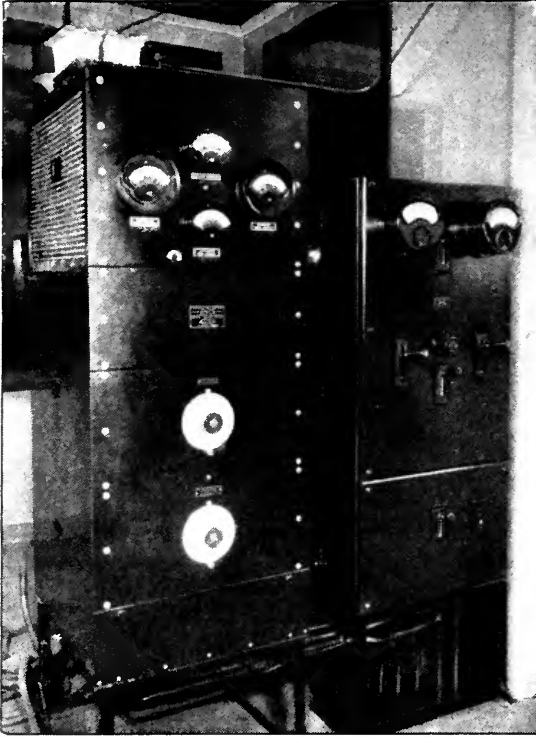

Detroit *News* Radio Broadcasting Installation. Transmitting panel at left. Control panel at right

Another point in last December's expansion of programmes was the securing of Finzel's Orchestra and other musical organizations with numerous members. These orchestras furnish music of various kinds, including dance music, and it is common for Detroit families to hold parties in their homes and dance to the music played by their favorite orchestra. The second Christmas concert presented by the *News* last year consisted of songs by carolers and addresses by Gov. Groesbeck of the State of Michigan, Mayor Couzens of Detroit and the Rt. Rev. Fr. John P. McNichols, president of the University of Detroit.

In February of this year the first concert by the Detroit Symphony Orchestra was broadcasted. Now every programme presented by that splendid organization is sent to music lovers not only in Detroit but over half of the United States. Expressions of enthusiastic appreciation from persons in all walks of life have followed this development of the *News* radio service. Contributions for the support of the orchestra have come from grateful people in a score of states who have thus been enabled to hear much finer music than could ever before be heard in the small towns

where they make their residence. The radio has opened new worlds of melody to music-hungry folk throughout the Middle West.

The *News* has received letters from Honduras, from Alaska, from Saskatchewan and Alberta, from Cuba, from officers on vessels on the Atlantic Ocean, from a ranchman in Wyoming, and from scores of other remote places, expressing thanks to the *News* for bringing across the great spaces such splendid music, such first-class theatrical entertainment and such rousing and stimulating messages from the leaders of the country's thought. All this has been extremely gratifying to those behind the project and has persuaded them that the great expenditure which the radio service has entailed has been amply rewarded in the consciousness of enhanced public usefulness.

A curious thing in connection with the broadcasting has been the reaction of stage artists to the undemonstrative little receiver into which they pour their songs and remarks. Frank Tinney refused to believe that he was not the victim of a hoax and that he was in reality not talking for the sole entertainment of the persons in the tiny auditorium where the transmitting apparatus is located. He was not convinced that a trick was not being played upon him until he heard music relayed back by telephone from Windsor across the river. This has been noticed in the case of almost every artist who is accustomed to applause as occasional motive power.

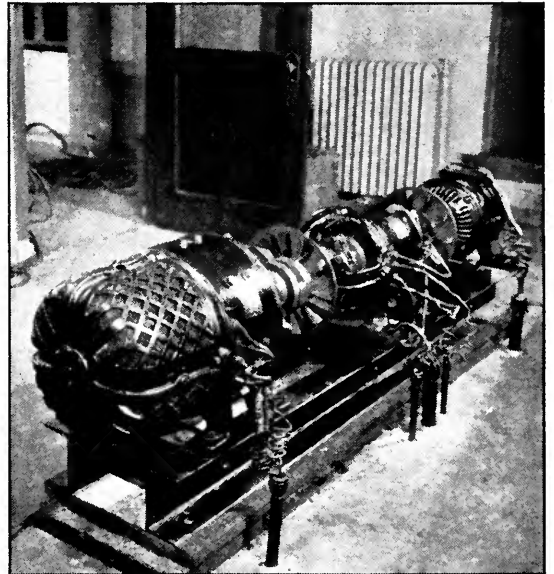

Detroit *News* Radio Laboratory Power Room

The *News* of Dec. 18, 1921, commented on this as follows:

"The receiver is not a very appreciative instrument, at least in appearance. One can't tell from the looks of the telephone whether his number is liked or not.

"This was quite baffling to Ernie Ball. He sang one or two of his most popular numbers, heard no applause and finally looked at the telephone in a manner that registered blind rage. And then he stuck out his tongue at the instrument which seemed to relieve his feelings a lot, for he swung immediately into another selection.

"In the case of Mr. Tinney, it was hard to convince that personage that this phenomenon was actually happening. Again and again he demanded to know if the thing were on the square, it was that uncanny. Of all the entertainers who appeared last week, Mr. Tinney probably suffered the most because of the absence of applause. The nature of his offering was such that it was almost necessary for him to have some demonstration of how folks liked what he was saying. This demonstration in all cases was not long in coming, for, at every concert, some of the appreciative listeners in flashed back their thanks and asked for more."

On the first of February of this year the installation was completed by the Western Electric Company of a 500 watt, 300 to 600 meter broadcasting set of the same type now being completed for the American Telephone and Telegraph Company on the roof of the Walker Lisenard Building, New York. Its power comes from two generators, one of 1400 and the other of 1500 volts, harnessed to a 5 H. P. DC motor. It is equipped with a specially high quality speech input arrangement, such as that used by President Harding at Arlington Cemetery last November, in which two No. 212-250 watt Western Electric vacuum tubes were used as oscillators and two more used as modulators.

One peculiarity about this set is the fact that, although it is only of 500 watt power when not in use, its power rises to 750 watts when

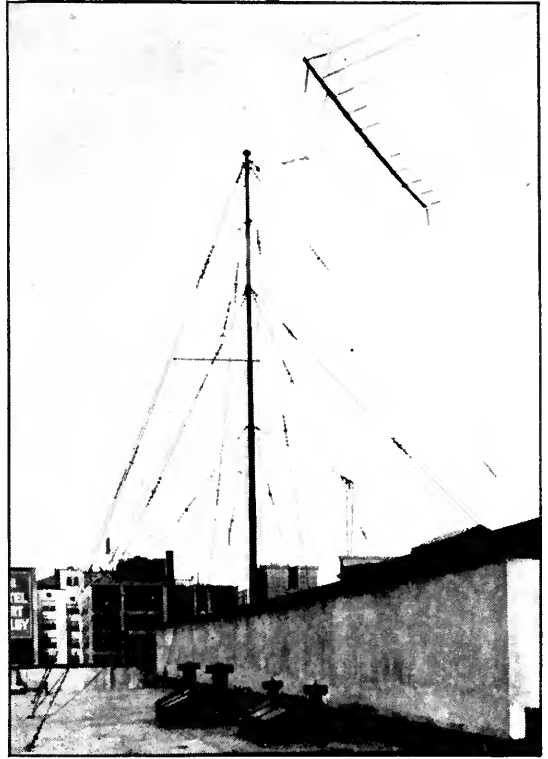

Aerial terminal on Detroit *News* Building

subject to conversation or music. Another feature is the fact that the power panel is entirely devoid of live points on its surface. All of the switches are concealed.

Since the transmitter used in the speech input section of the device is not as sensitive as the ordinary type, a Western Electric amplifier is used, which magnifies the voice about a hundred thousand times without producing any distortion.

This installation has an ordinary broadcasting radius of 1,500 miles, but reports have been received from points 2,300 miles away telling of successful receiving. The set was built to the special order of the *News* and is the only one of its kind thus far completed by the manufacturers. With this splendid equipment the *News* plans future radio activities on an even more elaborate scale than has thus far obtained.

# The Amateur Radio Laboratory

Its Equipment and Uses

By ZEH BOUCK

IT WAS only in recent years that I was initiated into the delights and facilities of a well-equipped radio lab. Until then I had been content (where ignorance is bliss) to struggle along with brace and bit, borrowed for occasions, a soldering iron, a can of Nokorode and the kitchen tubs when available. Being anything but a mechanic, indeed I preferred designing unlimited transformers to cutting a single piece of core for one, I was almost entirely dependent on uncertain electrical supply stores for parts and sundries, bent and twisted to the proper shapes. Thus it was not remarkable that the game was seldom worth the candle, and my homemade apparatus, possibly well designed but poorly constructed, was often less efficient than manufactured instruments purchased at a saving in time if not of money.

My radio tests and experiments were always limited by our neighbors' sense of humor and the physical characteristics of a city apartment; they found a meagre expression in spark and Tesla coils.

About the time of honeycomb sets my radio common-sense, spurred by financial considerations, determined me to buy my apparatus only, and to table the experimental and constructional end until circumstances warranted a lavish layout. My determination was stimulated by a friend, an electro-chemical engineer, who desiring to take up radio, came to me for aid in selecting his original receiving set. His knowledge of the subject was then altogether theoretical (he knew high frequency A.C.), and so was willing to act on any advice I might offer. Realizing that he possessed an electrical laboratory with some constructional facilities, I suggested that we make the set (I had a pet design in mind) rather than purchase it outright. He welcomed the idea and promised to procure the necessary parts which I had enumerated in a long list. But alas! I failed to caution him on the correlation of sizes and similar details that my own experience had given me cause to respect, and his final conglomeration of radio in the making was one

that would have stumped a better mechanic than I to put together!

I remarked sarcastically that the three sixteenths variometer shafts were hardly good fits for knobs and dials drilled with a quarter-inch hole.

"Oh, that's all right," my friend was undaunted. "I've got some quarter-inch rod around here; I'll drill it out and make sleeves!"

I next complained of the inferior jacks he had bought, commenting on how poorly their brass ends would show up against the nickle-plating on the panel. He merely smiled quietly and a quarter of an hour later they were nickle-plated and buffed!

I then preserved peace until on hooking up I found that my friend had supplied me with number twelve hard-drawn wire, which, in its adamant quality, was as difficult to work as a high-tension bus-bar. I struck then and there, but the engineer, not perturbed in the least, made some reference to an electric furnace, and taking the wire with him, left the room. Before I had cleaned the soldering iron, he returned with the wire soft and pliable. He had annealed it!

We worked steadily but without rush or over-exertion, and the afternoon of the second day saw the set complete and working! The apparatus combined long and short wave regenerative sets with a detector and two stage amplifier; an installation with a market value in excess of one hundred and fifty dollars, and which we had constructed for less than half that amount.

## II

In the radio laboratory I would first emphasize the shop. While electrical equipment is also of primary importance, the apparatus itself more than justifies, indeed demands, a well-stocked workroom. In the average lab consisting of two rooms, the workshop is separate from the operating quarters. Of this type is the laboratory of Messrs. Howell and Woodrow whose call, 2AQQ, is familiar to New York operators. A section of the shop

is generally devoted to a testing table with outlets tapped to all wires running to the operating room. There is easy access to antenna and ground connections, A. C. and D. C. lines, and in the case of three wire systems both 110 and 220 volts are available. Wires are usually led from the A and B batteries in the shack so that all working conditions can be duplicated in the shop and apparatus given practical tryouts before being permanently installed.

The tool equipment of the shop varies proportionally to the owner's pocketbook, and paradoxically it is often an inverse proportion. It invariably includes the conventional carpenter's implements augmented by such drills, saws, etc., as facilitate working with bakelite, metal, and less ductile materials. An assortment of taps and dies is almost as essential as the soldering iron with its inevitable can of Nokorode. There, too, is the ubiquitous set of drawing instruments (the dividers gradually wearing away under the stress of many sharp-edges) used in designing and laying out panels. In the more pretentious laboratories are found the bench lathe and drill press, tending through speed and accuracy to greater efficiency.

The accompanying photo shows the operat-

ing end of a radio laboratory in New York, owned by Mr. Henry Muller. This station, 2BH, stands an eloquent testimonial to the advantage of the well-equipped shop. The transmitting apparatus, a bulb set shown to the left, was designed electrically by the author, and constructed with meticulous attention to detail by Mr. Muller. All holes, with the exception of those inaccessible to the press, were drilled by machine. The large openings for the meters were cut by a power scroll-saw. The brackets were cut, drilled, and bent from massive strip brass, while the bushings and some back-of-the-panel construction are evidence of excellent lathe work. The core for chokes and the filament heating transformer were snipped from sheet iron and wound with commercial accuracy on a lathe. The tuning and amplifying cabinets show the intelligent use of good tools.

Indispensable to the radio lab are the raw materials with the almost infinite list of odds and ends. The miscellany of bakelite, hard rubber, brass and copper strips, nuts, bolts (six and eight thirty-two's predominating), glass, mica, "cabbages and kings" are of inestimable value when arranged in any semblance to system.



Operating table of an up-to-date amateur station (Radio 2BH)

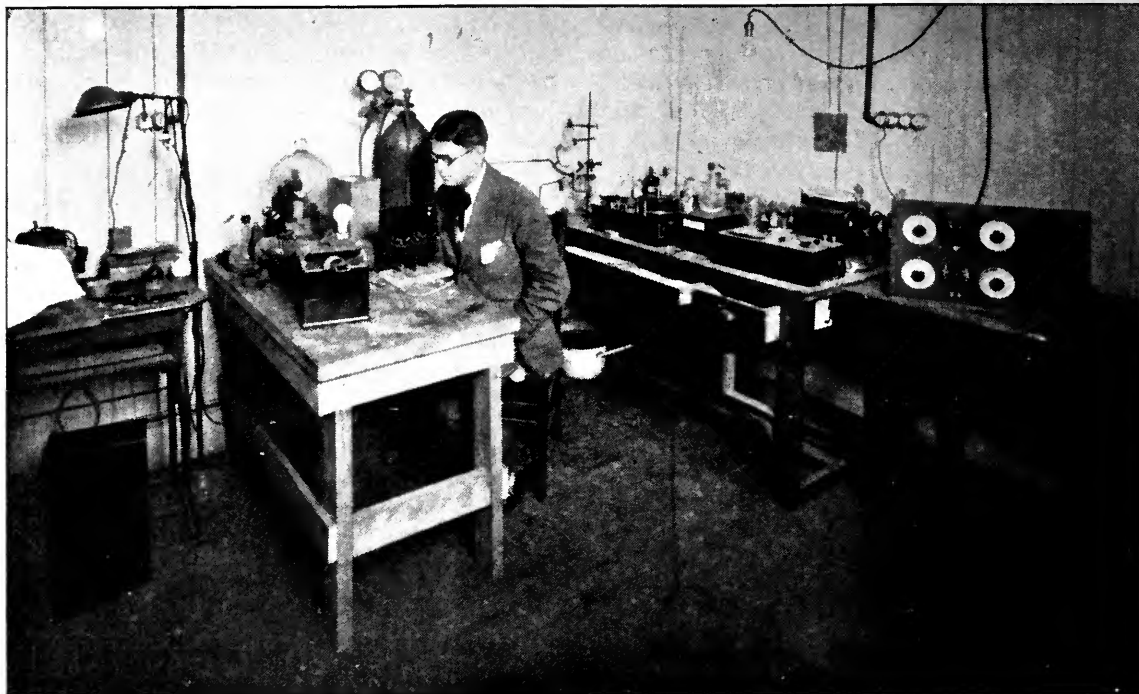

AMATEUR LABORATORY OF CHARLES P. MADSEN

Testing for faulty insulation. A partially completed receiving set is shown on the table to the right

The lab's electrical equipment is greatly dependent on the shop in which many of the instruments are designed and made. The actual transmitting and receiving apparatus is of first importance, and the photograph of 2BH gives an idea of the general trend in amateur shacks toward commercial lines. Mr. Muller's equipment, which has been partially described, is arranged similarly to a ship station which he operated for some time. The receiving set employs variometer regeneration on short waves, with honeycombs for six hundred meters and above, change from one to the other being effected by telephone switches in the centre panel. A loud-talker, operated from the second step, is not shown in the illustration. A possible and desirable addition to 2BH would be a spark transmitter, either 500 cycle quenched or 60 cycle rotary synchronous.

A charging system for storage batteries is another early consideration which, in the case of D. C., is easily installed by means of resistances or lampbank. If the station is wired only for A. C., some form of rectification must be employed; the most efficient methods being the two electrode valve (vacuum tube) and the motor-generator.

First among the radio frequency instruments is the wave-meter—in Mr. Muller's station, that prominent piece of apparatus resting on the detector cabinet. A dummy antenna, duplicating the capacity and inductance of the transmitting aerial, is indispensable for preliminary tuning without causing unnecessary QRM (interference). A small transmitting loop in conjunction with a single tube high frequency oscillator finds innumerable experimental adaptations. Nickle and copper plating equipment assures a uniform appearance to all parts without the irksome dependence on the electrical supply house.

A set of meters with auxiliary shunts and resistances is essential for electrical measurements. In delicate experiments the mil-amp and micro-volt meters are used in connection with a potentiometer, while in A. C. transformer work, such as the careful tuning of a spark transmitter, alternating current volt, amp and watt meters are required. For high frequency readings (radiation, etc.) a thermocouple meter is given preference over the hot-wire type. The direct reading ohm-meter (an English invention, known, I believe, as the Evershad Megger) is an instrument that is slowly finding its useful way into the amateur



laboratory. The invention, an ingenious arrangement, consists of a differential voltmeter actuated by a small hand-driven 250 volt dynamo. The device measures resistance with remarkable accuracy up to ten megohms (10,000,000 ohms)! The second illustration shows a testing table in the radio lab of Charles P. Madsen, New York City, with the author measuring the resistance between the blades of an amplifying jack by means of the ohm-meter. The radio apparatus, shown partially completed, was constructed in the lab by Mr. Madsen and myself. The result of the test indicated an unsteady resistance approximating ten thousand ohms (very low!) which was doubtless the cause of the microphonic rattling in the phones that we had been experiencing. When we wiped away a slight trace of soldering paste between the lugs, using a cloth moistened with methyl alcohol, the resistance rose to one megohm (1,000,000 ohms) with comparative quiet in the receivers and a noticeable increase in signal audibility.

A slide-rule and a dozen lengths of wire with test clips complete the equipment: this last, not a negligible item, but a most useful and integral part of the efficient whole.

### III

A laboratory such as the one described is, of course, beyond the means of many amateurs, that is in the sense of being the individual

property of any one of them. But it is fully within the resources of a well-organized club. With voluntary contributions of tools and apparatus, the financial disbursement should not exceed a few hundred dollars, a sum well invested and bringing in untold dividends of better equipment and a more comprehensive insight into our art.

But the determined enthusiast intent upon his own lab will not be discouraged by the expense of the layout described. A radio laboratory is not a thing collected or built in a day. It is rather the result of an extended series of purchases, the more complicated tools and instruments arriving year by year, with experience. After all, the implements themselves are but a secondary consideration, the ability of the experimenter always coming first. In the hands of a deft mechanic, wonders have been accomplished with a small hand drill, a set of six and eight thirty-two taps and dies, a light soldering iron (electric preferred) and a few household tools. Add to these a wave-meter, and the whole, exclusive of transmitting and receiving apparatus, will amount to some twenty-five or thirty dollars, and the amateur will have laid the cornerstone to the laboratory of his dreams.

Above all, strive for neatness and orderliness in the lab. It is a virtue, and though consistent with many virtues in being often missing, it is also always its own reward!

## Mistakes to Avoid in Erecting Antennas

By G. Y. ALLEN

J. B. WILSON of Reading, Pennsylvania, was visiting his friend Jim Black at Newark, New Jersey. That evening, at the dinner table, the conversation drifted to the wonders of radio, particularly to the latest achievements in broadcasting. Jim told how he and Mrs. Black scanned the programme as published in the daily papers, and how they "listened in" on evenings when they wanted some entertainment in much the same way as they would attend the theatre. He also went on to tell how the children liked

the "Man in the Moon" stories and as the company arose from the table, Mr. Black invited J. B. to come into the living room and "listen in" on the evening's entertainment.

"It's about eight o'clock now," said Jim, glancing at his watch. "They ought to be going. Here, put these on and see if I can tune him in," he continued, as he handed a spare head set to J. B.

Jim adjusted the crystal and moved the tuning handle over the scale, and soon J. B. heard Schubert's Ave Maria just as clearly as

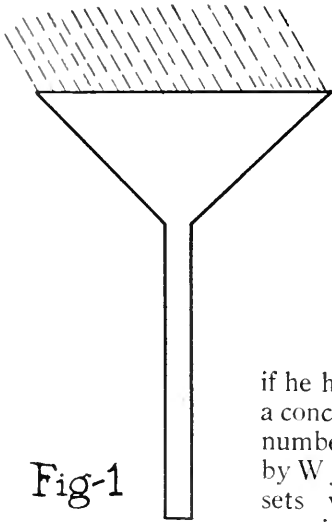

Fig-1

if he had been attending a concert. Several other numbers were rendered by W J Z before the head sets were removed to permit asking and an-

swering a number of questions that had come to the mind of J. B.

"The boy has been after me for some time to put in a set," said J. B., "but the landlord doesn't like the idea of a lot of wires strung on the roof of the apartment, and so I guess we'll have to wait until we move."

"Lot of wires?" said Jim. "Why, man, you don't need any wires. I'm getting this stuff on that bedspring in the next room. I just attach this wire to the spring and connect it to this terminal. You wouldn't want to hear that music better than I get it, would you?"

And so J. B. is finally convinced that a bedspring is all the antenna that is required under any and all conditions and he goes home, buys an Aeriola Jr., takes it up to his apartment in Reading, connects it to the bedspring—and hears nothing. The result is a very much dissatisfied customer and all on account of a little wrong information passed on by some one who was not wholly informed.

The antenna of a radio receiving set consists of the wire or wires

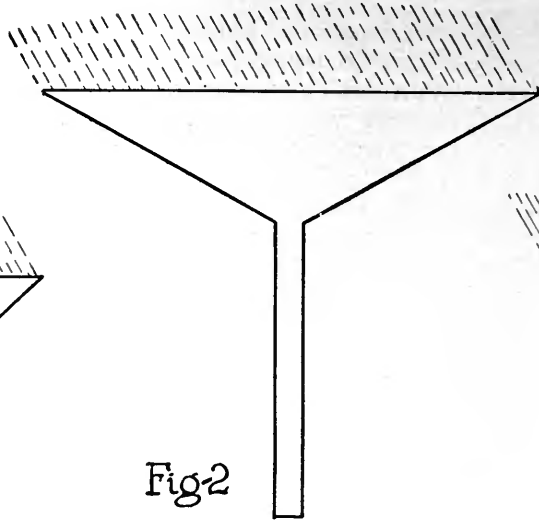

Fig-2

which collect the energy from the waves sent out by the transmitter. It is generally the most neglected part

of the set, and in the large majority of cases where satisfactory results are not obtained, assuming of course that the proper kind of a receiving set has been installed and that other fairly obvious conditions have been met, the trouble may be traced directly to a faulty antenna. Every one isn't as badly misinformed as J. B. was, of course, but there are other numerous pitfalls whose evil effects are not so obvious.

The strength of the sound that one hears from a radio set depends upon the voltage or electrical pressure created in the antenna by the waves from the transmitter and also upon the current, in the antenna wire.

A somewhat imperfect, but nevertheless helpful, analogy to an antenna wire is a large metal funnel supported above ground and connected to a rubber hose. Figure 1 shows a moderate size funnel corresponding to a small antenna. Suppose that a heavy shower is in progress. It will be easily seen that, if the rubber hose is not too large, the funnel will remain full and the water

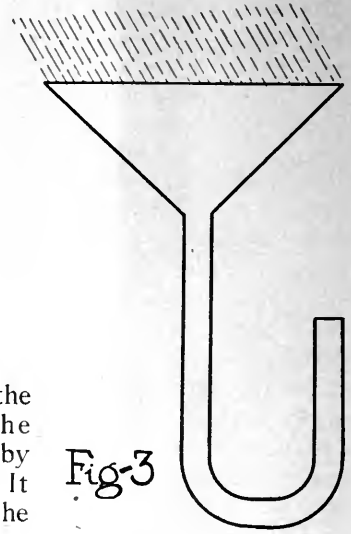

Fig-3

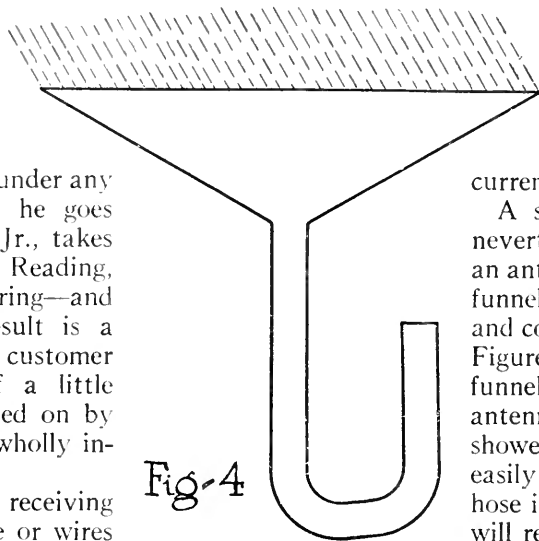

Fig-4

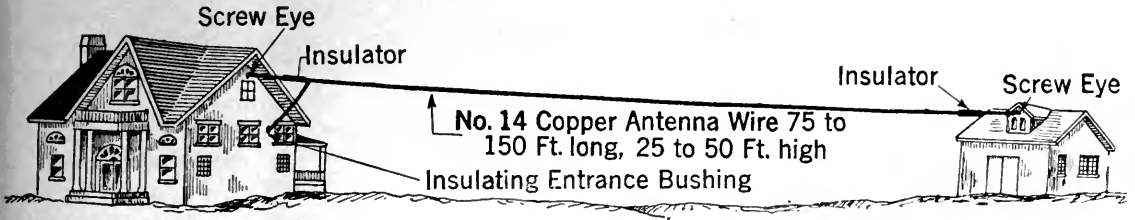

Fig. 5. Typical antenna for receiving from amateur and broadcasting stations

pressure at the lower end of the hose will be maintained constant. A smaller shower, however, will not keep the funnel full, and if the pipe pressure were to be maintained, a larger funnel, such as that shown in Figure 2 would be required.

When a radio antenna is located near to a radio transmitter, the waves striking it are comparatively strong. These strong waves will give good results on a small antenna. They correspond to the heavy shower maintaining the pipe pressure using a small funnel in the water analogy. However, when the radio receiving antenna is at considerable distance from the transmitter, the waves are relatively weak and they must be intercepted by a longer antenna to maintain the electrical voltage, just as it was found necessary to use a larger funnel to maintain pipe pressure in a light shower.

Another determining factor in the pressure at the bottom of the pipe in Figures 1 and 2, is the height of the funnel above the end of the hose. The higher the funnel, the greater the pressure. Similarly, the radio antenna should be placed high enough above the ground or the signal strength will be reduced.

A frequent mistake that is made in the erection of the antenna of a receiving station is in thinking that the only prerequisite is to get the wire or wires as high as possible regardless of any other conditions. In fact there is a tendency on the part of people living in tall apartment houses to feel that if they place their antenna on the roof, regardless of how close it comes to other objects it will function properly. The fallacy in this reasoning will be evident when it is realized that the electrical pressure on the antenna (one of the factors in determining the loudness of the signal) depends on how far the antenna is above grounded objects. The frame of apartment houses is generally of steel. This steel frame work

rests on the ground. Current is therefore free to flow up the steel frame and thus bring the ground pressure nearer to the antenna.

This can be better understood by referring to Figure 3 and 4. If the lower end of the rubber tube is made to approach the funnel, the water pressure at the end immediately decreases. Similarly when a radio receiving antenna is brought near to a steel frame apartment or to trees, or if the vertical wire connecting the antenna wire to the radio set (commonly called the lead-in) is run down an elevator shaft or through a conduit duct, the electrical pressure to ground is greatly diminished with a corresponding decrease in signal strength.

The erection of an antenna in such a way that wires come close to metallic objects resting on the ground is therefore equivalent to placing the antenna very close to the ground.

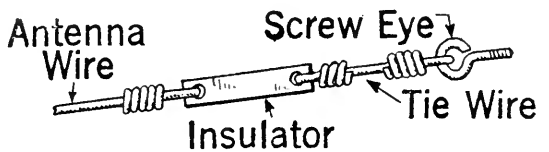
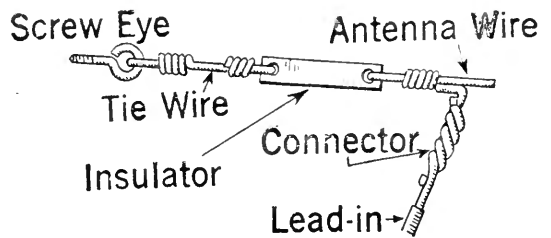

Fig. 6. Details of antenna construction

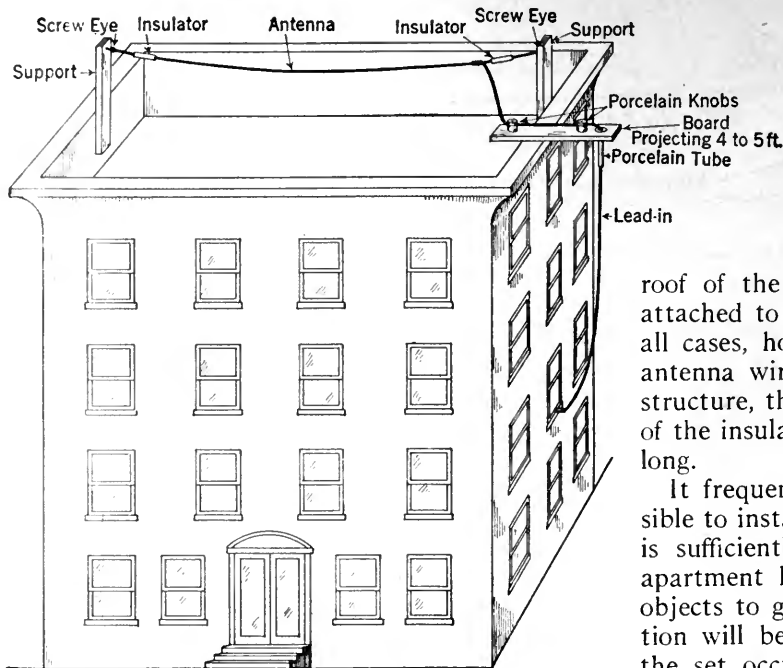

Fig. 7. ANTENNA ERECTED ON APARTMENT

In general the best form of an antenna for receiving from amateur and broadcasting stations is a single wire from 75 to 150 feet long and supported 25 to 50 feet high

Figure 5 illustrates an ideal antenna for use on a private estate. The wire should be not smaller than No. 14 B. & S. Gauge Copper or its equivalent. Any joints either in the antenna wire proper or in the lead-in should be as shown in Figure 6 or should be soldered. Twisted joints unless soldered are very unreliable, as they corrode. In fact, poor joints in the antenna wire frequently cause a falling off in signal strength as time goes on due to the corroding action.

If it is desired to install an antenna on the roof of an apartment house, the sketch shown in Figure 7 should be followed. The supporting posts should hold the antenna wire at least 15 to 20 feet above the roof of the apartment and the lead-in wire should be run over the side of the apartment as shown. In no case should the lead-in be run down an elevator shaft or through metal

conduit and it should be held from 2 to 5 feet away from the side of the apartment even if the wire be insulated.

If the apartment is so built that an elevator shaft or some other part of the structure rises above the

roof of the house, the antenna may be attached to it as shown in Figure 8. In all cases, however, where the end of the antenna wire is attached to a grounded structure, the tie wire on the ground side of the insulator should be at least 2 feet long.

It frequently happens that it is impossible to install the lead-in wire so that it is sufficiently far from the side of the apartment house and all other grounded objects to give best results. This condition will be experienced if the owner of the set occupies a lower floor of a tall apartment that is located very closely to an adjacent building. In such cases, the owner of the set must realize that he will not obtain as good results as his neighbor on one of the top floors. The most ideal place for the receiving instruments located in a tall building is on the top floor. Good results can, however, be obtained on the lower floors if proper precautions are taken.

At times, proprietors of hotels or of restaurants located on the ground floor of tall buildings install receiving sets with loud speaking devices and they are frequently disappointed in the results obtained. Unless properly informed, they have the radio receiver installed in the room where the music is to be heard and the lead-in will probably be led down near to the side of the building and in some cases will

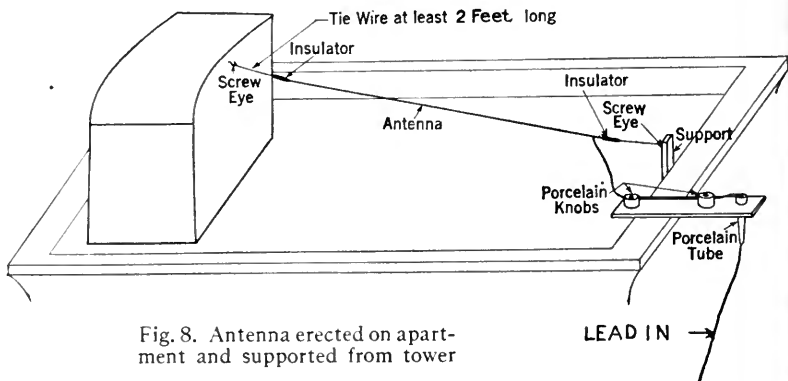

Fig. 8. Antenna erected on apartment and supported from tower

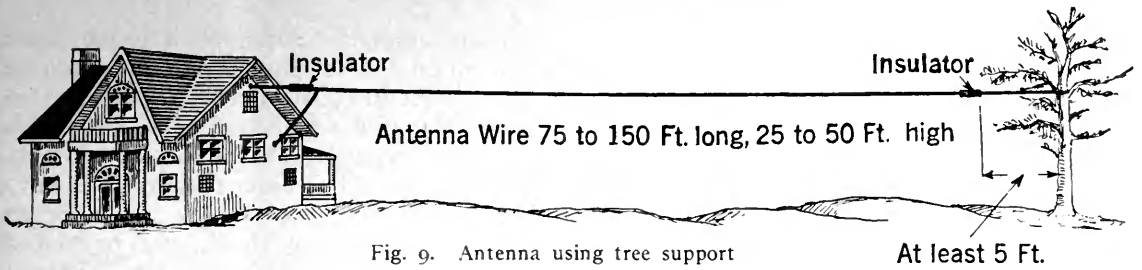

Fig. 9. Antenna using tree support

be brought several hundred feet through the building before it reaches the receiver. The abnormally long length of wire together with its proximity to grounded objects for a great distance will cause the set to give very poor results. The proper method of installing a receiver under such adverse conditions is to place the radio receiver on the top floor, if possible, running the leads from the amplifier to the loud speaker which may be located on the first floor.

If a tree is used to support one or both ends of the antenna, the tie wire should be long enough to permit the ends of the antenna wire to clear the tree branches by at least five feet. This is illustrated in Figure 9.

In the congested municipal districts and in certain localities less densely populated, considerable trouble may be experienced from noises caused in the radio set by near-by power lines. These power lines, particularly if they carry fairly high voltages, send out weak electrical waves of the same type as those sent out by a transmitter, and these waves may cause considerable annoyances on antennas in the vicinity. Contrary to the general impression, direct current lines cause more trouble in this direction than those carrying alternating current. The reason is that the frequency of the noise picked up from an alternating current line is so low that it causes comparatively little annoyance, whereas the variations in current occurring in a direct current line caused by the generators and motors connected to it is of such a high frequency as to be very troublesome at times.

If power wires are in the vicinity where it is desired to install an antenna, the antenna wire and lead-in should be placed as far as possible from the wires. The antenna should also be run at right angles, if possible, to the power wires. These precautions will reduce interference from power sources to the lowest point. In some cases where lines exist in more than one direction from the antenna location the antenna should be placed as nearly as possible

at right angles to both lines. In such cases the best location can only be determined by trial.

At times it happens that it is practically impossible to so place the conventional type of antenna that it is free from noises picked up from power wires. Or perhaps the owner of a broadcasting receiver is so unfortunately situated as to be located near to a radio telegraph station which cannot be "tuned out." Under such circumstances the most ready recourse is to a loop antenna.

The loop antenna consists of a wooden frame supporting a multi-turn rectangular loop of wire as shown in Figure 10. It is very directional in its properties, and by turning its plane toward the broadcasting station, all broadcasting is received with maximum loudness, and signals coming from other directions are reduced. Signals coming at right angles to the loop will not be heard at all. It is thus evident that if interfering noises come from a

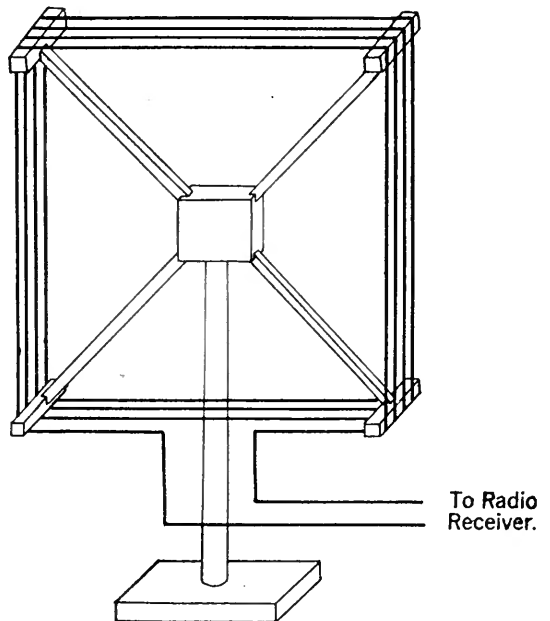

Fig. 10. Loop antenna

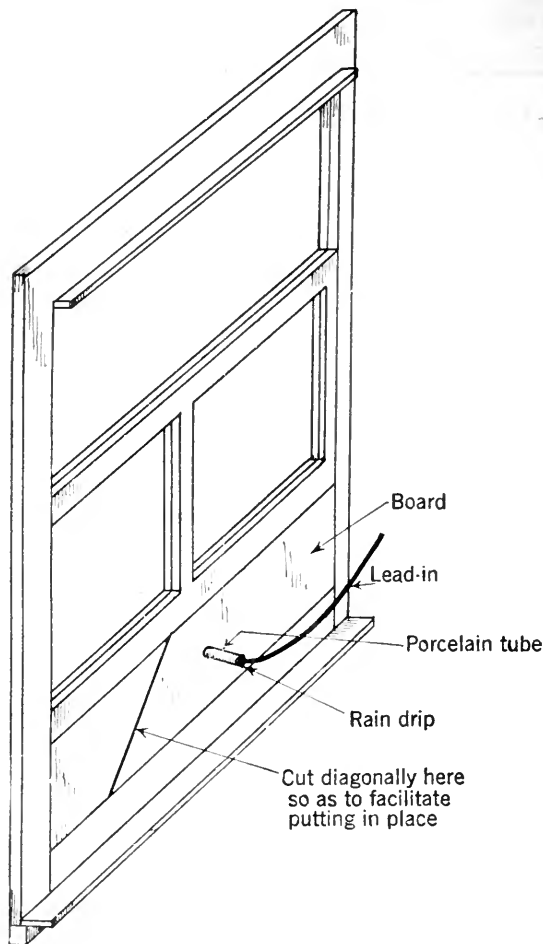

Fig. 11. Method of bringing lead-in into house

different direction to the broadcasting, their interference will be reduced.

The loop antenna does not pick up as much power as the conventional type of antenna, and unless the distance between the radio receiver and the broadcasting station is small, special apparatus involving high power radio frequency amplifiers is required.

In a frame house the lead-in may be brought into the room in which the receiver is placed by bringing it through a porcelain bushing in the wall of the house. In brick or concrete houses, the porcelain tube may be passed through a hole drilled in the window casing or a board may be placed under the window sash, and a hole drilled in it to take the porcelain tube. This latter method is shown in Figure 11.

The ground wire merits equal consideration

with the antenna. Although it is true that a ground on a water pipe in general cannot be bettered, yet in cases where it is necessary to run a long wire to a water pipe, better results may frequently be obtained in connecting to a steam or hot water radiator or even to a gas pipe. The ground wire should be as short as possible and should not be placed closely to the antenna wire. The antenna wire should never be taken into the building in the basement and brought to the radio set in close proximity to the ground wire. In fact the ground and antenna wires should be separated as widely as possible and both should be led in as direct a line as possible to their respective binding posts on the receiver.

This article on antennas would not be complete without some mention being made of lightning protection. Users of radio receiving sets and particularly landlords may rest assured that an antenna such as is erected for radio receiving is by no means as great a hazard as the telephone wires that can be seen running to any house. The radio antenna is hardly ever as long as the telephone connection between the house and the nearest pole and it is scarcely ever erected higher than a telephone line.

The Fire Underwriters Rules governing radio receiving antennas are now undergoing revision which will greatly simplify approval of small receiving installations by fire inspectors. Instead of the cumbersome knife switch that was formerly required, the use of a small enclosed gap in series with a wire to ground will be all that will be required, with the option of using a fuse to guard against possible contact between wires carrying high voltages and the antenna. There are now protective devices on the market which will doubtless be approved in the new revision of the code.

This article is not intended to create the impression that the installation of a radio receiving set is a difficult task. The thousands of successfully operating radio receivers bear evidence to the contrary. However, radio telephony reception like every other scientific phenomenon obeys certain laws. If these laws are not recognized, failure will result, but as long as they are appreciated and followed, radio telephony will be found to be one of man's most faithful servants.



# How to Begin to Enjoy Radio

CAPTAIN LEON H. RICHMOND, SIGNAL CORPS, U. S. A.

Editor, Technical Training Literature, Office Chief Signal Officer

Captain Richmond, who was Professor of Physics at Western Maryland College before the war, was commissioned in the Signal Corps at the outbreak of the war. After passing through various instruction camps, he was assigned to the Royal Navy (British) Flying Field at Cranwall, England, where he worked with Lt. Commander J. M. Robinson (British Navy) in developing a radio direction finder and other radio apparatus for airplanes. Upon the completion of this duty, and after a short time at an American Flying Field, he was assigned to duty at the Army Signal School, Langres, France, where he was in charge of the Radio Department at the signing of the Armistice. For the past year and a half, Captain Richmond has been on duty in the Office of the Chief Signal Officer at Washington.—THE EDITOR.

THE main topic of discussion at the International Radio Convention at Paris was radio wave lengths. The main topic of discussion at the "Hoover Radio Convention" held recently in Washington was radio wave lengths. It is the purpose of this first of a series of elementary discussions on radio to explain what is meant by wave length and to show why the subject is such an important one in the radio world.

Every one is familiar with some kinds of waves, especially with those that appear on the surface of water. Let us study these water waves. We can represent them by a line as in figure 1, where the curving line represents

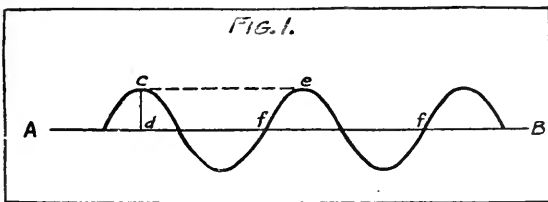

the surface of the water with waves on it and the straight line, AB, represents the surface of the water when there are no waves. The first thing we notice about a wave is its height. The stronger the breeze the higher the waves. The correct way to measure the height of a wave is to measure from the crest of the wave to the surface of the water when it is smooth. In figure 1 this would be represented by the line *cd*. A better term for this measurement is *amplitude* of the wave. Hereafter we will refer to the amplitude of the wave and not to the height. The reader should realize that in learning a new art, the learning of new words or new meaning of old words is probably the

most important factor. So through this series a term of particular application in radio will be italicized when it first appears.

If we have been in a boat or in swimming when there were waves, we are familiar with the fact that the waves have energy. In other words, they have power to move objects that are in the water or which they may strike. It is seen that the bigger the waves the more energy they have. Another way of saying this same thing is to say that the energy of a wave increases as its amplitude increases—a large amplitude gives a large amount of energy—a small amplitude gives a small amount of energy. In radio we use the energy of the radio wave.

If we watched water waves we would soon notice that besides height, the waves have length also. There would be a certain distance from one wave to the next. This distance can be measured from the highest part of one wave (called the crest) to the highest part of the next wave. This distance is the *length* of the wave. In figure 1 it is represented by the line *ce*. Also *ff* shows the length of the wave. The wave length, then, is the distance from any part of one wave to the *corresponding* part of the next wave. A short way of writing the word *wave length* is, " $\lambda$ " pronounced "Lambda." This symbol means wave length. (Write several of these symbols so as to become familiar with them.)

If we stood on the shore and watched waves go by we would notice that waves, besides having amplitude and length, passed us at regular intervals of time. Count the number of waves passing per second. You have counted the *frequency* of the waves. Frequency, then, is the number of waves passing

any point in a *second*. It is represented by the letter "n."

Suppose now that we wished to know how fast the waves are traveling. We could find this out in different ways. The easiest way to find it out is to figure it out as follows: Suppose each wave is 10 feet long and there was one wave passing per second. The wave must be travelling 10 feet per second, then, in order to get by. If two waves per second passed, then the waves must be travelling  $2 \times 10 \text{ feet} = 20 \text{ feet per second}$ . If there were 12 waves per second ( $n = 12$ ) and each wave was 10 feet long ( $\lambda = 10 \text{ feet}$ ) then the waves must be travelling  $12 \times 10 = 120 \text{ feet per second}$ . But  $12 \times 10$  is the same as  $n \times \lambda$  so that the rate of travel (velocity) of a wave is  $n \times \lambda$ . Velocity is always represented by the letter "v" so that  $v = n\lambda$ .

Now we have a very good idea of what water waves are. We can sum it up by saying that water waves are RECURRING displacements of water, traveling at a definite velocity and having definite *amplitude*, *length*, and *frequency*. These waves carry energy. This is true of water waves, and if we say "disturbance" instead of "displacement of water" it would be true of any kind of a wave. Waves are a recurring disturbance, traveling at a definite velocity and having definite amplitude, length, and frequency. Waves carry energy.

Each different kind of wave has a definite velocity. All kinds of radio communication is carried on by waves, called radio waves. The velocity of a radio wave is so great that it would go around the earth seven times a second if it could keep on going. That is a great speed. It is 186,000 miles in a second. In radio we do not measure distances in miles—we use meters (a meter is a few inches longer than a yard). The velocity of radio waves is 300,000,000 meters per second.

This velocity is CONSTANT, so that in measuring radio waves, if we can find either the frequency or the length, we know the other. This is true because  $v = n\lambda$  and  $v$  is always equal to 300,000,000 meters per second. So if we know either  $n$  or  $\lambda$ , the other one can always be obtained by dividing the known one into 300,000,000.

*Examples:* (1) What is the frequency if  $\lambda$  is 2,000? The frequency is 300,000,000 divided by 2,000 = 150,000 waves per second. (2) What is the wave length if the frequency is 50,000?  $\lambda = 300,000,000 \div 50,000 = 6,000$  meters. Sometimes one is stated and sometimes

the other. Both are known when one is, as we have just shown.

In order to have a wave it is evident that there must be some material to carry the wave. This thing in which the wave travels is called the *medium*. The medium that carries water waves is water. Sound is carried by waves in air. Air is the medium for sound waves. So for radio waves there is a medium which carries them. This medium is called the ether. Not much is known about the ether except that it will carry certain waves very rapidly. Besides carrying radio waves, it carries light waves and also heat waves. Another fact that is known about the ether is the fact that it is *everywhere*. It is between you and every other object. It is between the earth and the sun, the moon, and the sun, etc. It is in everything, as well as in the space outside. It is in the magazine you are reading—it is in your body. It is *everywhere*. There is no exception to that. You cannot think of a place where there is no ether—for there is no such place.

Radio waves, then, are carried by this ether. In order to describe these radio waves it is necessary to recall and explain some simple facts that are familiar. In combing your hair, have you ever noticed that sometimes the hair will follow the comb as it passes back over the head, even though the hair and comb do not touch? This is explained by the fact that the comb has been electrified. The comb ATTRACTED the hair, causing it to move. How does one object move another when there is no apparent connection between them? The lack of connection in this case is only apparent and not real. There is a real connection between the comb and the hair which is not visible to the eye. A large number of invisible *lines of force* pass from the comb to the hair. These lines of force have a peculiarity in that they always try to become shorter. In trying to shorten they move the hair toward the comb. The complete name of these lines of force is *electrostatic lines of force*, the name coming from the fact that the lines have power and are caused by stationary (static) electricity (electro). Electrostatic lines of force are present in a radio wave.

No doubt you have often played with a magnet and noticed that the magnet will attract pieces of iron even though it does not touch them. Bring a magnet near a nail and suddenly the nail will jump to the magnet.

Here again one object causes another to move when there is no apparent physical connection between them. Again the lack of connection is not real. There is a connection. *Magnetic lines of force* pass from the magnet to the nail and cause the motion in a manner very similar to that caused by the electrostatic lines of force. Magnetic lines of force are also present in a radio wave.

A radio wave, then, is composed of magnetic lines of force and electrostatic lines of force. A radio wave is represented in figure 2. This

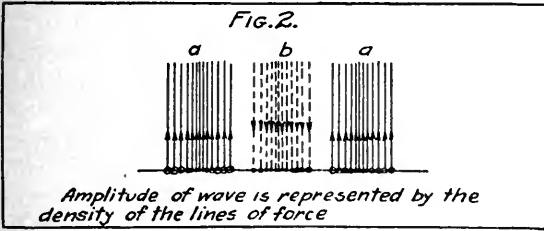

figure shows a radio wave moving from left to right. The electrostatic lines of force are represented by lines, the magnetic lines of force are represented by little circles at the end of the lines. It must be remembered that these are lines though they cannot be shown as such in a simple drawing. They extend at right angles to the electrostatic lines of force. In other words they extend away from you and into the paper as you look at the figure.

There is one other thing about a wave that we should observe. In a water wave we see that part of the water in the wave is above the level of the water when it is smooth and the other part of the wave is below the level. This is true of all kinds of waves—part of the wave disturbance is on one side of the usual (waveless) condition, and the other part of the wave disturbance is on the opposite side of the usual (waveless) condition. This is true of radio waves. Look at figure 2 and note that the arrows show that the electrostatic lines of force are directed upward in one part of the wave and downward in another part. This is also true of the electromagnetic lines of force. The open circles represent those that are directed toward you; the solid circles represent those that are directed away from you.

It must be clearly understood that this wave travels onward just as a water wave travels onward. This means that any point in the path of the wave is swept by lines of force, both magnetic and electrostatic, directed in one way and an instant later the same point is

swept by lines of force directed in the opposite way. Between each reversal of these lines of force there is a brief instant in which no lines of force sweep the point. As we already noted, the velocity of these waves is 300,000,000 meters per second. (They may be of any length; for example, as short as 50 meters or as long as 50,000 meters.)

An examination of figure 2 shows that the amplitude of the wave is shown by the density of the lines of force and that the wave length is shown by the distance between the densest part of the lines of force going in one direction to the densest part of the next series of the lines of force going in the same direction. All this can be very easily represented by a curved line as in figure 3, which is labeled the same as figure 2. Note how the curved line accurately represents the more complicated drawing of figure 2. The amplitude, which is represented in figure 2 by the density of the lines of force, is shown by the height of the wave in figure 3 (m). A radio wave is usually represented as shown in figure 3. It must always be borne in mind, however, that it is actually as shown in figure 2.

ENERGY OF RADIO WAVES

AS HAS been noted the density of the lines of force determines the amplitude, that is to say, the density of the lines of force determines the energy of the wave. Thus a very

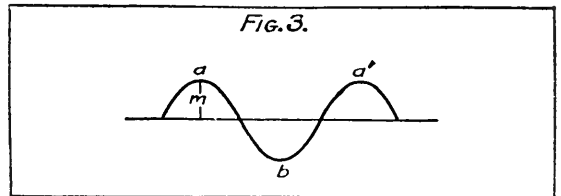

powerful radio transmitting station sets up radio waves having an enormous number of lines of force, a low-powered transmitting radio station sets up waves having only a comparatively few lines of force. As these lines of force sweep a receiving station they affect the instruments therein, the magnitude of their effect being determined by the amplitude of the wave. A radio wave spreads out from a transmitting station, the front of the wave spreading over a larger and larger area as it passes outward, in much the same way as ripples spread out from a stone thrown in a pool of water. As the number of lines of force in the radio wave does not vary, this means

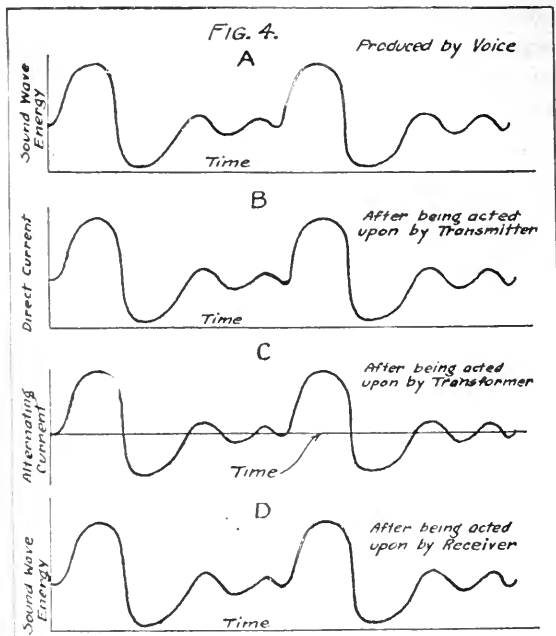

that the number present in any given area of the wave grows smaller as the distance from the sending station increases. Thus the farther a receiving station is from the sending station, the less energy it receives and the more difficult it becomes to pick up signals. The exact manner in which distance affects the energy in a wave may be expressed by a complicated equation. For our purpose it is sufficient to remember that the energy decreases much more rapidly than the distance increases. That is, a receiving station twice as far away from a transmitting station as another receives much less than one half as much energy as the nearer station; one three times as far away receives much less than one third as much energy. This is the usual thing but sometimes "freak" results that do not follow this rule occur. To sum up, the energy received by a station depends upon the energy sent out by the transmitting station and upon its distance from the transmitting station.

#### WAVE LENGTH SELECTION

A SENDING station transmits radio waves of a definite wave length. A receiving station is so arranged that it can pick up signals (energy) from a definite wave length. Of course the receiving station may be adjusted to many different wave lengths but when adjusted it picks up energy on one wave length

only. But it picks up ALL ENERGY on that wave length. It is the fact that receiving stations can so select energy from one wave length that allows more than one radio message to be sent through the ether at the same time. For example, suppose there were different stations transmitting, one on 300 meters, one on 400 meters, one on 500 meters, etc. Then a receiving station could be adjusted to select the 300-meter energy only and would not get any energy from the 400 or the 500-meter stations.

But if there were two stations in the same vicinity transmitting on the same wave length, say 300 meters, then the receiving station would pick up energy from BOTH transmitting stations. This would cause *interference*. This result would be very similar to that obtained when two people are talking at once on the same telephone line, or if you had two people talking to you through the same speaking tube at once.

There is, or was, in a certain city an amateur who had a radio telephone transmitter. Each night he turned on a phonograph and transmitted the whole evening. No one else in that vicinity could hold communication on that wave length because of the interference produced.

A definite wave length, then, must be thought of as a definite channel of communication through which one signal may pass but not two. If two signals are sent, the result is only confusing interference. Of course, if the transmitting stations are far apart, one signal may become so weak that there is no interference.

There are certain limitations in the radio transmitters and radio receivers which will not allow these wave-length channels to be too close together. That is, with ordinary apparatus, there cannot be one channel on 300 meters and another on 301 meters. This is because the apparatus is not perfect. This result may be approached however. The writer knows of one set which has been designed that allows nine channels of communication in a wave-length range of only two meters; from 74 to 76.

Here, then, lies the reason that wave lengths are the subject of discussion at the radio conventions. There are so many radio stations of different kinds that some control over their wave length must be exercised, otherwise a great many stations will be using the same wave length with consequent interference. Wave lengths must be controlled by someone

just as a telephone line is controlled by the telephone company. If there were no control, there would be no radio communication, for a great many people in the same vicinity would try to use the same wave length at the same time, with the same result, so to speak, that would occur if a great many people tried to use the same telephone line at the same time.

#### SOUND WAVES AND THE VOICE

**S**OUND waves are waves in air. The air is alternately compressed and rarefied; the compression corresponding to a crest of the wave, the rarefaction to the trough of the wave. A simple sound is made up of only one of these waves. More complex sounds are composed of a number of these waves. The voice, for instance, is a complex sound having, for a man, one wave whose frequency is about 250 per second, another of 500 per second, another of 750 per second, and so on. The wave of the lowest frequency is called the *fundamental*; the other waves are called *harmonics* or *overtones*. It is the number of harmonics present and their relative amplitude (strength) which make it possible to distinguish one voice from another.

#### WIRE TELEPHONY

**I**N ORDINARY wire telephony the sound waves produced by the voice are caused to produce, by means of a *transmitter*, a variation in a direct current; the variation in the current being identically similar in amplitude and frequency to the sound waves which produce it. This variation in direct current is usually converted, by means of a transformer, into a variation in alternating current which is similar to the variation in direct current. The variation in alternating current is then by means of a *receiver* converted into sound waves, the sound waves being identically similar in amplitude and frequency to the alternating current which causes them. As this identical similarity of amplitude and frequency has been maintained throughout the complete cycle, the sound waves produced by the receiver are identical with those originally produced by the voice. The series of events outlined above are represented by the curves of figure 4. The sound wave is represented in A of figure 4 in the same way as a radio wave is represented in figure 3. Each crest of the wavy line represents a compression of the air particles and each trough represents a rare-

faction of the air particles. It is noted that the sound wave is a complex one.

The instruments peculiar to wire telephony are the transmitter and the receiver. The transmitter, sometimes called a microphone, has two conductors separated by granules of carbon. The sound waves strike a flat piece of metal called a diaphragm and cause it to vibrate. The diaphragm acts upon the carbon granules, alternately increasing and decreasing the pressure of the granules upon one another, as it vibrates to and fro. This variation in pressure between the carbon granules varies the resistance of the granules. A direct current which is flowing through the granules is varied by this varying resistance. This varying direct current is changed into a varying alternating current by means of a step-up transformer. The alternating current acts upon the receiver. This receiver consists of an electromagnet through which the alternating current passes, and a permanent magnet which forms the core of the electromagnet. Mounted in front of the poles of this combination magnet is a flat piece of metal containing iron. This is also called a diaphragm. The alternating current causes the diaphragm to vibrate, thus producing the sound made at the transmitter.

(It is realized that the above paragraphs contain some electrical terms with which the reader may not be familiar. These will be explained in later articles.)

#### FUNDAMENTAL METHOD OF RADIO TELEPHONY

**I**N RADIO telephony methods are employed to produce at the transmitter and reproduce at the receiver a sound wave, that is, a

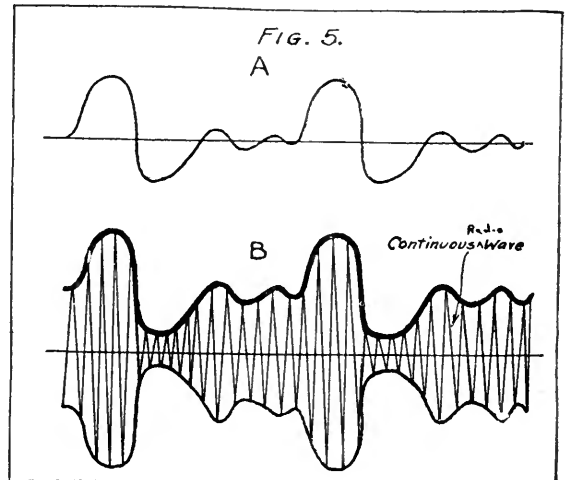

wave similar in character to that of figure 4. It has been found possible to do this by varying the amplitude of the radio waves so that this variation in amplitude follows in detail the wave variation produced by the sound. In figure 5, curve A represents a simple sound wave.

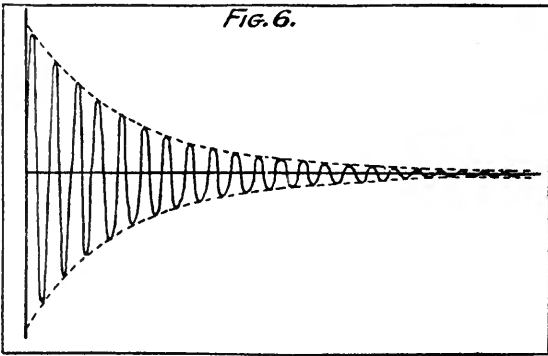

By means of methods to be described later the amplitude of a *continuous* radio wave is varied so that the variation in amplitude follows identically the amplitude and frequency of the sound wave. This is shown by the heavy line in B of figure 5. This line, together with the lower inclosing line, is called the envelope of the radio wave. Note that the upper and lower inclosing lines have the same shape. The radio wave is said to have been *modulated* when it was made to undergo the variations in amplitude. By means of the receiving apparatus, the heavy line shown in figure 5 B affects the receiving telephones. This causes the sound as explained in the previous paragraph.

To sum up, then, radio telephony is made possible by the fact that the radio waves are so modulated that their amplitude changes according to the voice waves. Figure 5 B represents very accurately what occurs. One may think of the whole process as a wave carrying a wave. The carrying wave being the radio wave, the carried wave being a wave which by means of the receiving apparatus is transformed into a sound.

#### KIND OF RADIO WAVES

**R**ADIO waves can be classified into *damped waves*, *undamped waves*, and *continuous waves*. A damped wave is a wave in which the energy gradually decreases with each succeeding wave until it finally vanishes. In other words, the amplitude of the wave is first large then grows smaller and smaller until the wave

disappears. A damped radio wave is represented in figure 6. The heavy line is the wave and the dotted lines follow the diminishing amplitude. A damped wave is the easiest wave to produce and for years was the only kind of a wave used in radio communication. The series of waves shown in Figure 6 is called a *wave train*. Damped waves can be used in radio telegraphy only; that is they cannot be used in radio telephony. It will be shown later that even a single dot in the Morse code by telegraphy is composed of very many wave trains. It is to be realized, then, that in using damped-wave communication, the signals are composed of a great many wave trains and that between these wave trains there is a space in which there are no waves.

An undamped wave is a continuous wave, though a continuous wave is not always an undamped wave. This is like saying that a dog is an animal though an animal is not always a dog. The name continuous wave defines itself. It is a wave that does not die out; in other words, it is unbroken. The amplitude of the wave may vary but it never is zero. A very good example of a continuous wave is shown in figure 5, where it is so labeled.

An undamped wave is a continuous wave whose amplitude does not vary. The wave shown in figure 1 represents an undamped wave, for its amplitude is constant. The terms undamped wave and continuous wave are often used interchangeably. Continuous wave is the broader term. Accurately speaking, undamped waves cannot be used in radio telephony for, as we have shown, the method of radio telephony involves the changing of the amplitude of the radio waves.

Undamped waves have certain advantages over damped waves for use in radio communication. They carry much more energy in the same amount of time. For instance, suppose a dot used in radio telegraphy lasts one twentieth of a second. Using a wave length of 1,500 meters, there would be in undamped-wave transmission, 10,000 waves in this dot. If this dot was sent out by damped waves there would be, if a wave train occurred 1,000 times a second, 50 wave trains in the dot. If each wave train consists of 40 waves—a reasonable number—the total number of waves in a dot would be 2,000. Thus there are five times as many waves in the undamped-wave dot as in the damped-wave dot. But the damped wave has only one of its waves at maximum ampli-



tude and the rest gradually die away while the undamped waves have every wave at maximum value. For this reason, the energy of each undamped wave is in this case about five times the average energy of the damped wave, providing the maximum amplitude of the damped wave has the same value as the undamped wave's amplitude. Thus the energy in a dot carried by the undamped wave is 25 times the energy in a dot carried by the damped waves. This is a great advantage, especially as it does not take much more power

to generate the undamped waves than it does to generate the damped waves.

It is because of the above reason that practically all long-distance radio telegraphy is carried on by undamped waves. These waves also permit of a method of reception which greatly enhances their value over damped waves, though it is more difficult and requires more apparatus. There are other advantages of undamped waves which will be considered as more is learned about the radio art.

## The Pacific Coast Is "On the Air!"

By WILBUR HALL

**T**HIRTY years a Californian, I can remember three "crazes" that have swept the state and with it Oregon, Washington, and the contiguous mountain states, like measles in a boarding school.

Twenty years ago we went mad over Belgian hares. We paid as high as \$2,500 for a buck, and some of the gold cups presented to "best young does" and "best Imp. sires" were big enough to float a yacht in. To-day the Belgian hare is worth just what he'll bring for frying, and no more.

Ten years ago (or such a matter) we went dippy over roller skating. It was being done, and the liniment market was extremely bullish, while fortunes were made by the manufacturers of ball bearings, electric pianos, and court plaster. To-day roller skating is practised exclusively on the front sidewalk, and the only doctor's bills are paid by stout gentlemen who can't get out of the way quickly enough.

The third period or era of the Far West may come to be called the "loose coupler-detector-and-one-stage-of-amplification age." Instead of their symptoms, elderly women on our boats and trains and in our sewing societies discuss the number of stages of amplification necessary for DX reception. Women's clubs have abandoned the question of whether or not Bacon wrote Shakespeare, and are forming cliques over the dispute: "Who should be eliminated from the short wave-lengths?" Business men ruin their digestions at noon, not with politics

or financial rows, but with deep discussions involving the Heising constant current system of modulating the oscillator tube output. As for the boys (and a good many of the girls) their cry is: "Hey, Skin-nay; c'mon over! I'm getting the band concert at Catalina!"

Despite the fact that in the neighborhood of San Francisco there are located two or three of the earliest and most important radio telephony laboratories of the country, and the further fact that it was from here that several of the most vital improvements in the new service originally came, especially during the war, the average man on the street had never more than vaguely heard of radio until two months ago. Amateur operators, mostly boys, had been dabbling with wave-lengths and detectors and all the other mysterious factors and agencies; perhaps a hundred men were working at it—experimenting, testing, inventing, installing, improving, and looking forward to the big rush that was to come. But the layman gave it the same attention as he did the newspaper stories that the Akooned of Swat was to take unto himself another wife.

All of a sudden it hit us!

The first most of us saw of it, beyond random and rather dull newspaper and magazine accounts of developments, was in first-page, first-column headlines from New York, not over two months ago, proclaiming that the East had gone mad over radio.

Within twelve hours the interest swept the Coast.



© Underwood &amp; Underwood

Henry Ford listening to radio. He is reported to be a radio enthusiast and may well be thinking of a way to send crop reports to farmers with Ford tractors and "flivvers"

We found out at once that the new marvel had already established itself among us like the flu—quietly and insidiously. We found out that hundreds of our youths had been "on the air" for some time. We found out that engineers were ready to install any kind of plant we wanted, either for receiving or for broadcasting.

But what amazed and perplexed us, and still does, was that if we wanted anything in the radio line except copper wire and roofs to string our antennæ on, we would have to go down on a waiting list as long as that of the Bohemian Club, and that we would be lucky to get service inside of three months.

If we postponed action for three days, we went to find that the waiting list had quadrupled in length and that six months or maybe eight was the best we could hope for.

Naturally we thought someone was kidding us and we had to be shown that, for the better part of a year our local electricians, inventors, and manufacturers had been making radio stuff as fast as they could, working day and night, that they had enlarged their facilities twice, three times, ten times, and still were

swamped, and that every one of them was shipping sets East.

Perhaps this whetted our appetite for radio. At any rate, there isn't a complete receiving set of any sort to be had on the West coast to-day and there won't be for months, except for those who are on the list.

If it weren't tragic to them, it would be comic to see the bafflement in the eyes of local radio men.

"What's the present state of the radio business here?" they echo, vacantly. "You tell 'em! We don't know. We're out of our depth, and going down for the third time! We're working three shifts; we are fighting for raw materials; we are combing the country for men who know the business; and we are so far behind now that it doesn't look as though we'd ever catch up. Radio has caught on like grease in a Greek restaurant kitchen, and all we've got to fight it with is water in a teacup!"

The most amazing feature of it all to me is that, for the present at least, the only use for radio is "stunt" shooting. A few scattered receiving stations are making practical use of the radio in the matter of crop and weather reports and forecasts, the day's news, and so on. But practically all the activity now is about the dissemination of "concerts" played on the phonograph. The fact that every home that can have a radio receiving set can, and probably does, have a phonograph, seems to make no difference. People will sit for hours listening to Caruso sing or the Victor Band play through the air who wouldn't walk across a room and wind the old cabinet and get the same music home-grown. To this extent it is all a fad, and this phase of it will pass.

But the potentialities of the business are interesting. It is certain that, for one reason at least, the West will find greater use for radio than the East; said reason being that out here our distances are greater. What does that mean? Simply this: that radio annihilates distance, and the more distance there is to overcome the greater and more important the feat.

Concretely I mean something like the following:

Along the Atlantic Coast I suppose there are comparatively few homes of the middle or better class without a telephone. No one is more than a few miles from a telegraph station. Few live outside the delivery zones of daily newspapers. You can reach every human be-

ing in New York, for example, within eight hours, if you have to and hump yourself sufficiently.

On this Coast, to the contrary, four fifths of our area and probably two fifths of our people live beyond the range of easy communication. Mountain ranges, unfordable and unbridged rivers, and desert wastes intervene. You have to go around where you can't go across. If a political candidate, to take an example, wanted to communicate with every voter in the three Coast states, it would take him ten years to do it and by that time so many youngsters would have come to the voting age that some galoot in Woodland or Bellingham would probably have been elected by a plurality of thirty thousand and would have given away all the post-offices and made himself solid with the constituency and good for four terms.

Along comes radio. And I have made up my mind, since pursuing this elusive and mystic subject for the kind editor of this publication, that inside of a year there will not be a person in the Pacific Coast states who will not

have or be within easy reach of a receiving station that will give him the hot stuff just as it comes from the old griddle.

I mean that—no less.

Taking only the matter of our mines, oil fields, and scattered ranches. To-day the men on some of these properties and places are about three weeks behind the rest of civilization—and in that length of time, as life moves to-day, you could kill off a couple of foreign potentates, divorce the country's best-known actress and marry her again, drive copper up to twelve cents or wheat down to sixty, and develop nineteen brand-new movie colony scandals in Hollywood. To-morrow—or the next day, at latest—the mine owner can order a new tunnel driven or two hundred men fired in half an hour, from his city office or club; the petroleum operator can take options at the rate of one a minute or can receive hourly reports of progress on a deep hole; the commission man can buy eggs or barley or cotton at one and the same time in Astoria, the Walker Lake reservation in Nevada, or in the heart of the Colorado

Here's a boy who has done it. George Frost, 18 years old, president of the Lane High School Radio Club, Chicago, has equipped his Ford automobile with a radio receiving set



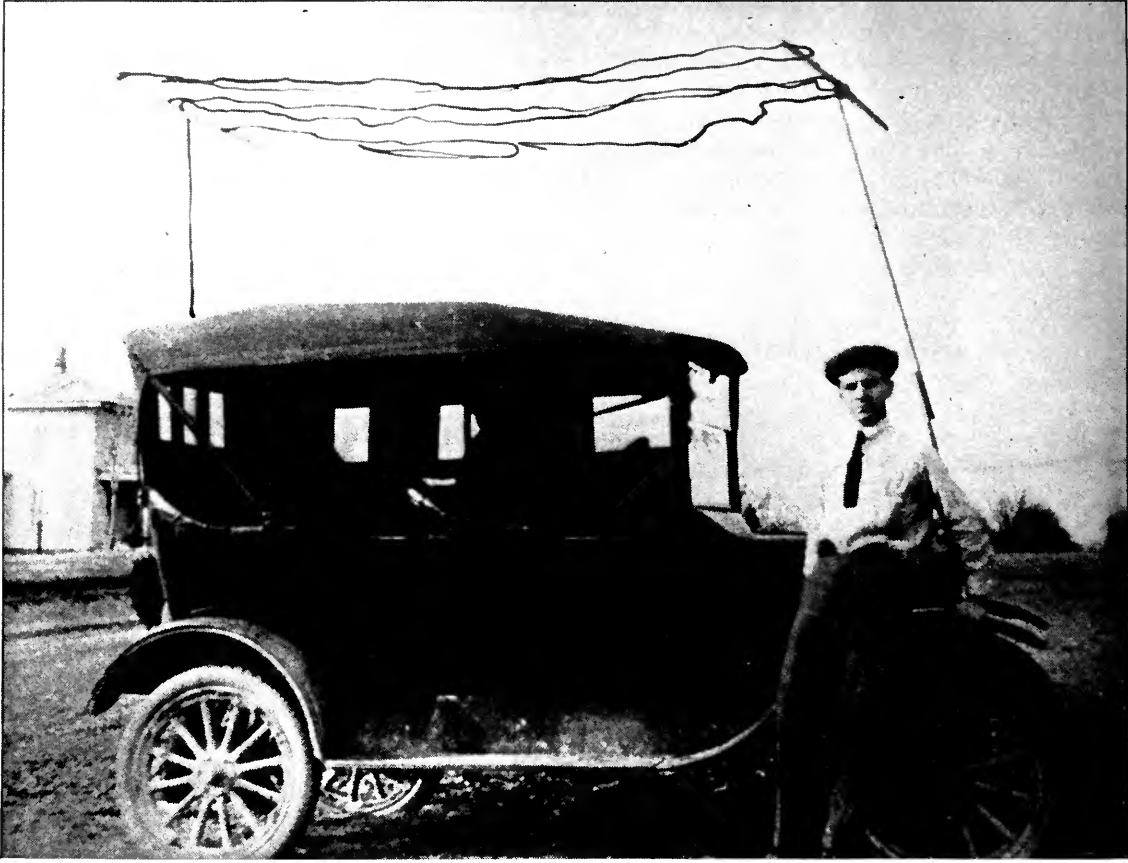

Not pretty, but it works. This radio installation put on his Ford by "Bud," Slocum, a 16-year-old sophomore in Ionia High School, Mich., is not as neat and compact as those to be installed on California's automobile stage lines—but it works

desert, and eat a sandwich at Fourth and Market streets, San Francisco, while he's so engaged.

Another instance (out of hundreds) is that, potentially, of the man operating a mountain resort. At present he and his guests are at one end of a tenuous telephone or telegraph wire, and between them and civilization are mountains, deserts, gulches, wastes, and unmapped wilderness, with nothing but the wire to depend on, and no assurance that a hawk pursuing a nimble English sparrow won't put that out of commission at any hour of the day. I make no doubt whatever that every resort and camp in the West will this summer be advertising daily news dispatches, concerts, fashion notes, and society items within an hour of the time that the man who stayed in the city gets them warm from the press. And the field is still left wide open for men who go into still more remote places, on business or

pleasure, and who to-day might slip over a cliff or break a rib and lie for days, weeks, or months, as the case might or might not be, before any one found him—or his body.

For once I think we are safe in asserting that the wild and woolly West is at least up with, and perhaps something ahead of, the East. Conservative estimates put the number of receiving sets operating on the Pacific Coast and adjacent states at 25,000. The estimates run as high as 50,000 and, counting home-made sets which are increasing at an unbelievable rate, this is probably more nearly correct. Some of our lads out here are receiving messages daily and taking in concerts that are dispatched from points as far distant as Japan and the Atlantic Ocean, and the excellent and lively radio magazine now published here and already in (I believe) its fourth year has a couple of pages of "Calls Heard" reports that will make any Easterner sit up and tune up.

They claim, I understand, that there is a scientific gentleman in Los Altos of Sunnyvale, just south of San Francisco, who has heard farther than any man in America with his extensive and elaborate set, and he is engaged now in experiments on improved devices that, he and his company say, will multiply the practical usefulness of radio ten-fold. And so on. The friendly rivalry that exists between operators of radio outfits has done more, as Mr. Herbert Hoover has observed, to hasten the perfecting of the new practice than fifty years of laboratory work would have done under normal and non-competitive conditions.

The first successful station on the Pacific Coast, both for broadcasting and receiving, was the army one, established at the Presidio, in San Francisco, at about the time of the close of the war. This is one of the best-equipped stations here still, and has done a lot for radio on the Coast. There are now at least two broadcasting stations in Seattle, one large one about to be completed in Portland, if not one in Reno, Nevada, and possibly scattering ones in the other states hereabouts. They go in so fast that no one pretends to be able to keep track of them and there is, of course, nothing as yet that is official. In California the bay region about San Francisco is far ahead, with approximately twenty broadcasting stations, several of them finely equipped and with a great range. Los Angeles has caught the craze now and several installations are being made.

One interesting possibility just hinted at to me may be unique. California has, I believe, more long-distance automobile stage lines than any other state. At present the State Railroad Commission is working very hard to make these lines a real public utility and as dependable as to running time, stops, number of cars operated, and routes followed as it has already made them standardized as to rates charged. The principal difficulty has been to maintain a fixed schedule or time-table. But already one of the largest of the companies operating in this field, itself new, is making plans to equip each of its stages with a small receiving set and to dispatch its drivers and keep in touch with them on the road by radio. Here, again, the West has a use for the radio that may never be so acutely felt, if felt at all, in the East.

All the San Francisco newspapers and sev-

eral in other cities are now publishing a radio page. This all in the last few weeks. The University of California has extension course lectures on practical radio-telephony and the classes are over-crowded. A tight organization, known as the Pacific Radio Trade Association, is functioning fully and trying intelligently, and already with some success, to bring order out of the present chaos of broadcasting. The Association has already issued a schedule of hours when the air can be grabbed by the many who want it, and its officers—sound men in the business—are now looking forward to the time when one central broadcasting station will be erected. If this is not done soon by the government or one of the powerful companies or combinations, the Trade Association will undoubtedly take the bull by the horns and do it itself. It means business.

Much of my information comes from an amiable young gentleman named Rathbun associated with the Colin B. Kennedy Laboratories, of San Francisco, and I want to quote him a little to make clear how radio has developed here.

"When I left the army," Mr. Rathbun said; "I had two or three business propositions made me, but I took the one that paid the least and, to my friends, seemed to have the poorest future—a position with this company. It was organized by Mr. Kennedy in June, 1919, and he had one office boy and a mechanic. I took the work up because I felt pretty certain that within ten years, and perhaps within five, there would be a general and widespread interest in radio telephony.

"I was mistaken. When the blaze flared up it took six months to reach greater proportions than I had ever dreamed it would reach under five years. Now the company employs sixty-five people and is putting on more every day. We are seven months behind our orders, which come from all over the world, but in a few weeks we hope to have our facilities increased to the point where we can catch up to within three months, at least.

"The growth of the business has not been even like a mushroom's development—it has been like the bursting of a shell."

It seems not too much to hope that, within a year or so, the Pacific Coast will hear faint rumblings of the news about radio. Not too much if you are a hopeful person.

# Adventures in Radio

Perhaps no other branch of science enjoys the romance and the spirit of adventure ever present in radio. It matters not whether it is the radio telegraph or the radio telephone, one has as many advantages as the other in this respect. Of course, radio telegraphy is the older of the two, and its exploits are more numerous; up to now, it covers a wider field of endeavor on both land and sea.

Aside from the everyday uses of radio, there are a great many instances in the history of the art which stand out as milestones in the march of progress; instances which few devotees of radio broadcasting know about. Many of these adventures were unique—not always possible or practicable to duplicate; on the other hand, some were accidents, others mere incidents, still others great adventures; adventures never to be forgotten and which stand out as red-letter days for the individuals concerned.

By adventures in radio we mean that which deviates radically from the commonplace. Radio has been responsible for many innovations—many new uses, some of which passed out of human ken, others were repeated again and again until to-day we have ceased to wonder and be thrilled when we chance to read newspaper accounts of such doings. Thus, we have the Radio Reporter, the first authentic instances being that of reporter Sprague of the Los Angeles *Examiner* who, pressed for time and urgently desiring to “scoop” the other sheets, commandeered the radio telephone set of a local army officer in order to report an unusual sporting event. Then there is the Radio Detective who came into his own during the war and of whom more will be said in a future number. The Radio Doctor has again and again proved his worth at sea, and many a sailor owes his life to a medical consultation held by radio from ship to ship or from ship to land. The initial success of the Radio Actor, or Actors, who have broadcasted an entire play over the radio telephone still rings in our ears. Then we have radio as the leading factor in the lives of the gunrunner, the smuggler, the arch criminal, the Central American revolutionist, the international spy, the cast-away sailor, and so we might go on indefinitely, for the exploits of radio are legion; some of which stand out as monuments of scientific achievements; others are ignominious ones to which this noble art has been unwittingly subjected. All of these, nevertheless, are intensely interesting, breathing the very spirit of adventure and romance.

To this end, it will be the purpose of this department to report each month radio adventures that actually took place, with real human beings as principals. The series will range over the entire world, with incidents taking place in Sweden, Patagonia, and far-off Japan, as well as in the United States.

The editors would be glad to receive accounts of such radio adventures from readers of the magazine, either their own experiences in the first person or authentic experiences of others.

## Married by Radio

By PIERRE BOUCHERON

THESE have been all sorts of marriages, happy, unhappy, and otherwise. There are conventional marriages taking place in the church, or at the court house, or at home, and the bride and bridegroom are face to face, or side by side when the union takes place. They can always take one long look at each other before the fateful step and call all bets off if either one changes his or her mind. There, at least, is one advantage of conventional marriages. But marriage by radio takes a certain amount of faith, hope, and charity as well as a strong belief in science.

There is the case, for instance, of Wakeman versus Ebert, who probably broke the world's record for long-distance marriages—long distance in the sense that when the event took place they were separated by a few odd thou-

sand miles and their “yes I do's” were carried to each other across this vast stretch by means of the etheric waves of radio.

This first long-range marriage by radio took place in May, 1920, the Girl, Miss Maybelle Ebert, being in Detroit, and the Boy, John R. Wakeman, somewhere on the Pacific Ocean on one of Uncle Sam's battle wagons, the cruiser *Birmingham*.

About 8:30 in the morning, while the *Birmingham* was in mid-Pacific, the radio operator called for Wakeman, one of the sailors, with an important radiogram. It was an unusual sort of message and lacked the usual naval lingo referring to orders, transfers, target practice, arrivals, departures, or provisioning.

When its nature was made known to the ship's captain and chaplain, the entire crew was mustered on the after-deck with sailor



Wakeman as the central figure. The ship's powerful 10 kilowatt transmitter was started and the entire ritual of the marriage ceremony was repeated slowly by first the three individuals on board—the minister, the sailor, and the operator—then through an etheric stretch of nearly 3,000 miles to the First Presbyterian Church of Detroit, Michigan, where were assembled the bride, her friends, and the minister. While Miss Ebert and her friends were grouped about the minister, the latter telephoned the bride's side of the ceremony to a near-by telegraph office from which it was wired to the powerful radio station at the Great Lakes Naval Training Station near Chicago. From there, the ritual messages were flashed to and from the ship in mid-Pacific.

While it is true that the messages had to pass through several intermediaries before reaching their respective destinations, not much more time was consumed than would

ordinarily occur at a conventional wedding. The above unique event required the combined use of the radio, the land line telegraph, and the land line telephone.

Since this incident, there have been all manner of radio weddings, short and long distance, by land, by sea, and by air. Some of our readers may recall the aerial wedding of Lieutenant Burgess and Miss Jones during the annual New York City Police Games of 1919. While this was a real honest-to-goodness wedding, it was more of a spectacular event than one of necessity. The bride and bridegroom flew in an army airplane over the huge crowds gathered below. Behind them in another airplane was the "flying parson" who performed the ceremony.

Below, near the grand stand, several loud speakers had been installed so that the crowd could hear the entire ceremony as carried on above by radio telephone between the two planes.

Here is how Uncle Sam keeps track of every ship in the United States Navy. Captain E. C. Kalbfus is on the ladder, and Assistant Secretary of the Navy Roosevelt (left), and Rear Admiral W. C. Cole, assistant chief of naval operations, are below. Each of the four walls of this room at the Navy Department is covered with a large blackboard devoted to a different fleet, and the ships' movements are reported by wireless



## Sunk by Radio

**N**O, RADIOITE, it was not John Hays Hammond's radio torpedo in action, nor was it the German submarine *U-10* sent to the bottom by the duplicity and cunning of a British torpedo boat destroyer. It was a peace-time incident. It occurred off the semi-tropical and balmy coast of one of the Bahama Islands, and it was for the "movies" and in order that you, John, Maggie, and little Jimmie might be thrilled some evening while sitting in the little red "movie" house around the corner.

One morning of January, 1914, the tramp steamer *Camaguey* dropped anchor off Nassau, and the crew proceeded to the pleasant pastime of leaning over the rail while waiting for the local boarding authorities to come out from shore to pass inspection, preliminary to discharging a general cargo of merchandise. Close by lay a huge sailing boat painted the most vivid yellow imaginable, a yellow which covered sail, mast, body and all superstructure. What looked like lazy sailors were stationed here and there perfectly motionless and likewise clothed in the saffron scheme of the rest of the outfit. It was a strange sight this yellow "flying Dutchman" riding peacefully at anchor while the early sunlight played beams here and there on its vast expanse of yellow-hued sail.

The last rumble of the *Camaguey's* anchor chain had no sooner died down to respectable quietness when a speedy launch darted out from the other side of the yellow ship and

turned its bow toward the *Camaguey*, full speed ahead. In a short time the launch reached the side of the bigger craft and an excited individual jumped up from the stern end and yelled to the Captain to move the position of his ship to a point as distant as possible from the yellow craft as something drastic was about to happen. The e. i. being dressed in the office of a local authority, the Captain of the *Camaguey* accordingly picked up anchor again and moved to another point of the bay.

Meanwhile, the wireless operator had observed that the yellow craft was equipped with a radio antenna. Following the strong instincts of his kind and wondering what it was all about, he accordingly repaired to his "radio shack" and with his gaze centered on the strange craft began to call "CQ, CQ, CQ," which is the general call asking any one within hearing distance to reply.

For answer, he heard a loud, sonorous spark of close proximity telling him to please stop sending for at least 15 minutes. The operator continued to gaze out of the porthole across the calm surface of the lagoon at the yellow ship as if fascinated and with the head telephone receivers still on his ears.

Presently he heard a series of unintelligible dashes, sent slowly and perfectly timed, one following the other, then silence, then a few dots, then more dashes. It was all very strange, for they seemed to be so close that he reasoned they were being transmitted by the



Radio antenna among the palm trees in the Bahamas

# Radio panels

**H**AVE your panels made to your own specifications. Celoron Radio Panel Service assures you the highest type, best serving, best looking radio panels made, machined and engraved to your own individual specifications.

**Condensite Celoron Grade 10**—the highest type of radio insulation that we produce—has a wide variety of uses in the radio field. It is extremely high in surface and volume resistivity, high in dielectric strength and low in dielectric losses. Particularly suited for panels because it machines easily, engraves beautifully and is extremely handsome in appearance. This is the grade we recommend. It has been approved by the Navy Department Bureau of Engineering.

Where economy is a factor we can supply panels made of Vulcanized Fibre Veneer. This material is made of a center section of hard, grey vulcanized fibre veneered on both sides with a waterproof, phenolic condensation product. It has a fine, smooth, jet black surface, machines readily, engraves nicely and is applicable for use in the construction of radio equipment where very high voltages at radio frequencies are not involved.

Celoron Shielded Plates (patent applied for) are made with a concealed wire mesh imbedded directly under the back surface of the plate. This wire shield, when properly grounded, very effectively neutralizes all "howl" and detuning effects caused by body capacities. Made in both grade 10 and Vulcanized Fibre Veneer.

## Send to-day for our Radio Panel Guide

Are you an enthusiast? Write to-day for our Radio Panel Guide that describes these panels in detail—quotes prices—and tells you just what the panel you want will cost.

Are you a Radio Dealer? Get in touch with us. Learn how easily Celoron Radio Panel Service enables you to sell panels completely machined and finished to your customer's specifications. No waste, no bother. Write for our special Dealer Proposition to-day.

## DIAMOND STATE FIBRE COMPANY

**Bridgeport (near Philadelphia) Penna.**

**Branch Factory and Warehouse, Chicago**

*Offices in principal cities*

In Canada: Diamond State Fibre Co. of Canada, Ltd., Toronto

yellow ship. Yet perfect stillness prevailed on board and even a pair of binoculars trained on the "lazy" crew failed to show the reason for the strange behavior of the craft.

Meanwhile the speedy launch had turned about and was making for a large float about a half mile in the offing where considerable paraphernalia seemed to be centred, with a group of men moving about from one instrument to another.

Slowly, the dashes were repeated, then the dots, then silence. Finally, a long dash was heard lasting fully a half minute, at the end of which the horror stricken operator saw a blinding flash dart from the centre of the yellow craft followed by a monster cloud of dense smoke, then a terrific explosion. The sails, mast, superstructure, sailors, and antenna were hurled high into the air and in a few minutes the smoke had cleared and the débris had settled near the spot where the doomed ship had been. It was indeed a horrible sight, a terrible tragedy. What had happened?

Just then it occurred to the operator to train his glasses on the distant barge. What he saw now was three perfectly collected and calm individuals gathered about a man who was *cranking away at a moving picture camera* "shooting" the last scene of the ill fated craft's end. Another movie tragedy with radio playing an unseen rôle had just been enacted.

Briefly, the yacht was painted yellow that it might better register on the film, the lazy sailors were dummies set up for local color, the barge held the directing party. A short distance away on shore was erected a portable spark transmitter which had sent the dashes and dots actuating a master relay and control drum on board the craft which in turn performed several functions, the final one that of igniting a powerful charge of explosive. The tramp steamer operator had witnessed a near drama assisted by radio, where the yellow craft had almost made its getaway with the millionaire pirate on board as part of the story's plot.

## Making Radio Sales Pay

By ARTHUR H. LYNCH

**R**ADIO broadcasting has proceeded at such a rapid pace that we now find haberdasheries and drug stores going into the radio retail business. This condition is not good for radio and it is doubtful that such stores will long continue to thrive as dispensers of radio products.

Even some of the largest department stores, in the cities where radio broadcasting is being carried on, are not suitably equipped with personnel to render the proper service to their radio customers. A few days ago, while making a small purchase in one of these establishments, a radio man overheard a clerk in the radio department explaining to a customer that a certain receiving set could be used with a loop antenna for the reception of broadcasted wireless telephone concerts over very great distances. The customer appeared sceptical, so the enthusiastic clerk plunged into a long story, using a lot of technical words which actually meant nothing to the customer, but which he thought would make a favorable im-

pression. Unfortunately, the customer believed the clerk and purchased the outfit.

Most of the technical language indulged in by the clerk was nothing more than hearsay, and his contention that the set would function satisfactorily over the long range he had mentioned was absolutely false.

Barnum said the public likes to be fooled; perhaps he is right, but it would be pretty safe to assume that after attempting to secure the wonderful results pointed out as possible by the clerk, the customer who purchased the radio outfit from a reputable department store would return the outfit to the store for credit and the store itself would be in a fair way to lose a good customer.

The importance of stopping such a course of procedure as this cannot be overestimated and those in charge of the radio merchandising departments, whether they be in department stores or electrical supply houses, should make every effort to be sure that the men behind the counter really know the possibilities of various

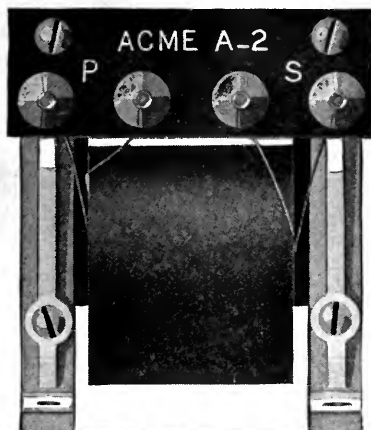

Model A-2S  
Amplifying Transformer  
Price \$5.

## —and whispers become living voices

WHEN you add one stage of Acme Amplification to your receiving set, music and dialogue assume a depth and roundness totally lacking in the ordinary detector circuit.

Throw in two stages of Acme Amplification, and sounds come in volume so distinct that you can use a loud speaking device—the *real* way to hear broadcasting.

Acme Amplifying Transformers are built with specially designed closed iron cores which prevent howling and distortion. Why not buy the best, they cost no more.

*For sale at good radio stores.*

**The Acme Apparatus Company**

CAMBRIDGE, MASS.

*Transformer and Radio Engineers  
and Manufacturers*

New York Sales Offices,

1270 Broadway

# ACME

## TRANSFORMERS

*Manufacturers of*  
Acme Amplifying Transformers

Acme C-W Transmitting  
Apparatus

The Acmeophone

Acme One Stage Amplifying Units

Acme Two Stage Amplifying Units

Acme Detector Units

Acme Detector and Two Stage  
Amplifying Units

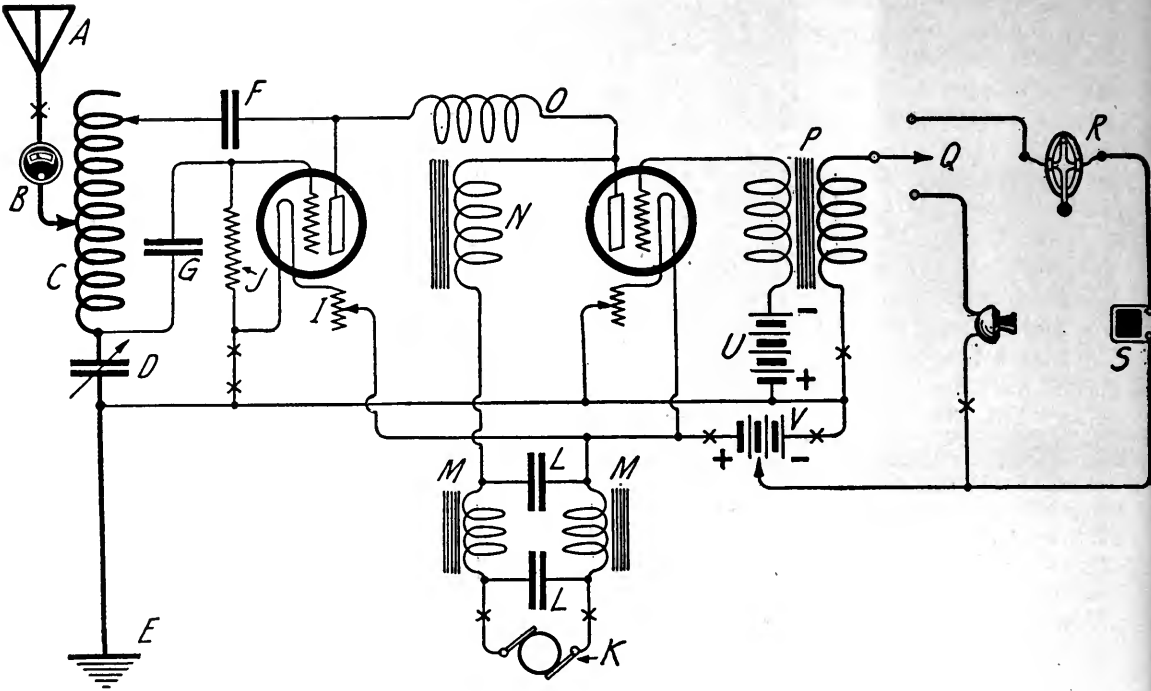

Fig. 1. Illustrates complete 5 watt radio telephone and buzzer-modulated radio telegraph transmitter. The assembly is entirely made up from stock parts and designed for use with direct current power supply. A motor-generator is employed for supplying the plate voltage.

types of equipment and in no case exaggerate the results which are likely to be obtained.

There is a growing tendency, even on the part of employees of the most representative radio companies in the country, to treat customers with little or no consideration. This is more or less natural, for the demand for radio apparatus is so great that if a sale is not made to Bill Jones, Dick Smith races in with a check in his hand all primed to relieve the radio dealer of any superfluous material he may have on hand.

Sales people in radio supply stores naturally become tired explaining to Tom, Dick, and Harry that their stock of What Nots is exhausted and that it is not likely to be replenished for a few days or a week, especially toward the end of the day after the same story has been told many many, times. However, the customer may also have put in a rather strenuous day in his office or at his bench, and is likely to resent the indifference on the part of the salesman.

Indifference of this sort grew during the boom time in business in the late war. The sales people in practically all the stores in the country became very independent, as did the

stores themselves. The natural reaction was that the public soon found that it was possible for them to do without some of the material they formerly considered necessary, and when the stores eventually secured quantities of the material, previously very scarce, the public had learned to do without it. This very same condition is rapidly growing in radio circles, and it is very regrettable. Can we not nip this tendency in the bud?

RADIO DISPLAYS

The accompanying illustrations serve very well to indicate the parts necessary for assembling a complete wireless telephone and telegraph transmitter for use with either alternating or direct current. Where direct current electric light systems are found, it is necessary for the amateur to use a motor generator for supplying the necessary plate voltage for the vacuum tubes. Where alternating current is available, however, a suitable method for transforming and rectifying the current is supplied by units now on the market which offer the dealer a very attractive source of revenue. By assembling a complete transmitter upon the base, having the wiring plainly



# Crystal or Vacuum Tube Detection with the same set



Model AR-1300

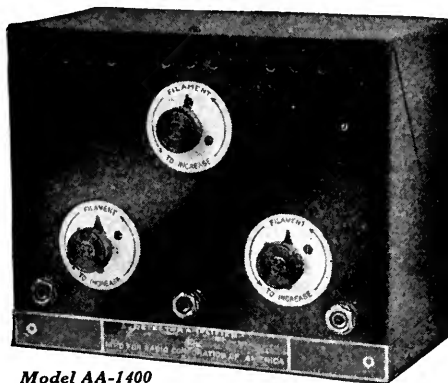

Model AA-1400

These two sets (radio receiver Model AR-1300 and Detector Amplifier Model AA-1400) meet the demand of the novice who wishes to start with a simple crystal detector and later to pass on to vacuum tube detection and amplification at minimum cost.

Radio receiver Model AR-1300 is a new tuner for the broadcast enthusiast. Used as a crystal detector it is a complete receiver. Used with Model AA-1400, here shown, the crystal detector is switched off and amplification is controlled by regeneration.

Detector Amplifier Model AA-1400 consists of a vacuum tube detector and two stages of audio-frequency amplification. It

is especially adapted for use with receiver Model AR-1300 to increase the strength of broadcasted concerts. The individual filament control permits close regulation of the received energy. Distortion of broadcasted music is avoided by a special high-frequency resistance across the secondaries. Three telephone jacks insure ideal selectiveness ranging from simple tube detection to two stages of amplification.

PRICES (NOT INCLUDING ANTENNA, TUBES, AND BATTERIES)

<i>Radio receiver Model AR-1300</i>	. . . . .	\$50.00
<i>Detector Amplifier Model AA-1400</i>	. . . . .	75.00
<i>Total for Combination</i>		<u>\$125.00</u>

See these New G. E. Products at Your Nearest Dealer



Sales Department, Suite 1807  
233 Broadway, New York City



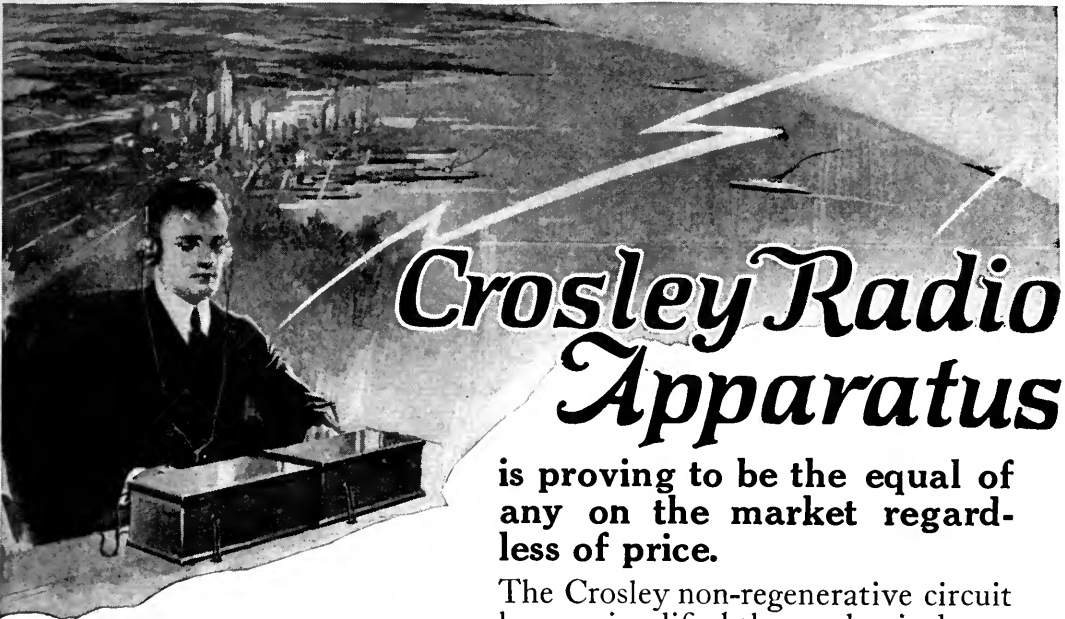

# Crosley Radio Apparatus

is proving to be the equal of any on the market regardless of price.

The Crosley non-regenerative circuit has so simplified the mechanical construction of Crosley Radio Apparatus that the low prices might be mistaken for an indication of cheap merchandise.

Crosley Radio goods are quality goods. Quantity production is also responsible for the reasonable prices at which they are sold.

## Crosley Harko Senior Detector and Tuner

This highly efficient tuner and detector will of itself without amplifier bring in from hundreds of miles, concerts loud and clear with head phones alone. The hook-up is Crosley non-regenerative, efficient, yet simple. Detroit, Pittsburgh, Chicago, Newark, N. J., etc. are heard regularly in Cincinnati with this single instrument. Parts are substantial, well made and finely finished. The cabinet is mahogany finish, \$20, without batteries, head phones or tubes.

**\$20**

*This Harko Senior receiver (pictured) in Denver, Colorado, without amplifier picked up Dr. Chas. Steinmetz's lecture in Schenectady, N. Y.*

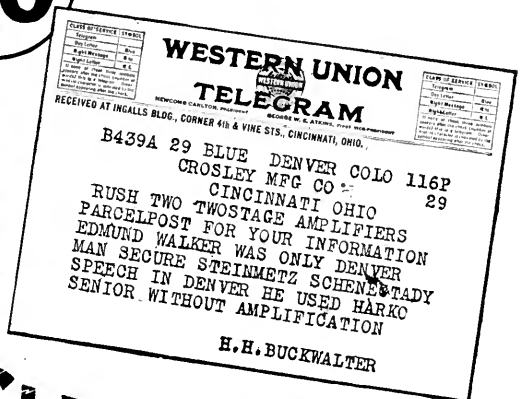

Other Crosley receiving apparatus, table and floor designs, completely illustrated in our catalogue. If dealers cannot supply you write us. Some distributing territory still open.

**CROSLY**  
**Manufacturing Co.**  
 Dept. RB-622  
 Cincinnati, Ohio

Write us for our Radio Parts Catalogue.

All radio accessories guaranteed tested and efficient. Low prices prove our slogan, "Better-costs less."



This is the complete layout for a 10 watt wireless telephone transmitter

several different companies, which can be employed in a circuit of this character, a circuit diagram should be shown with a symbol

for each unit indicated by a letter. The price list should carry not only the actual units in the assembly but also those the dealer has in

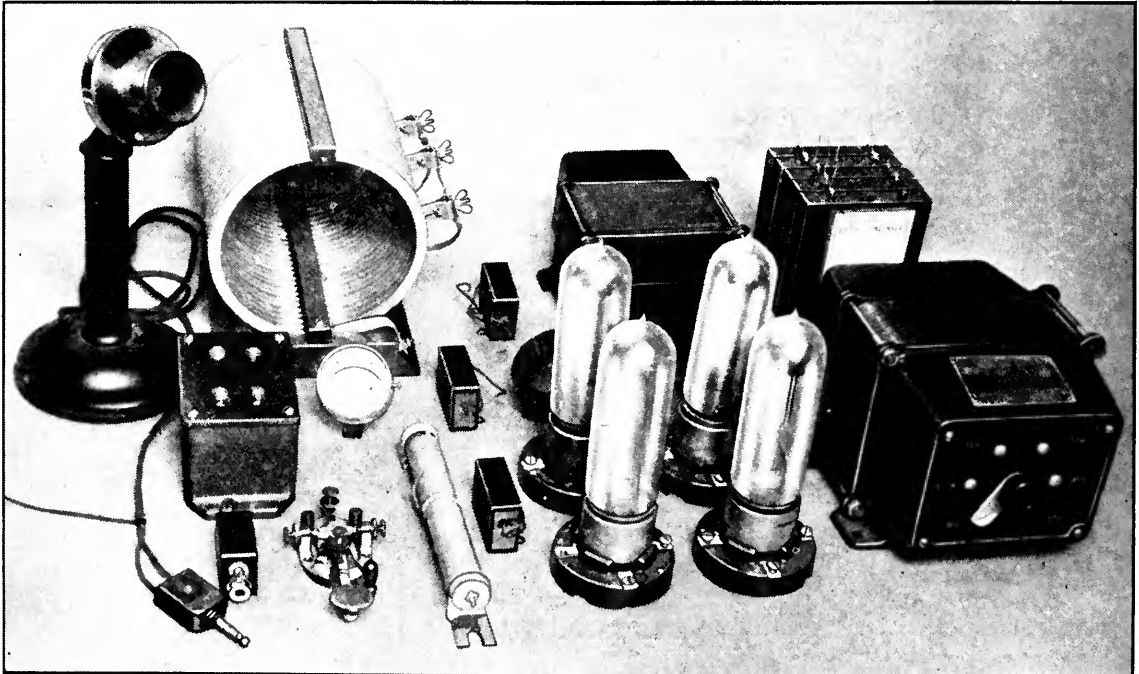

All the necessary parts for a complete 100 watt wireless telephone or telegraph transmitter are shown\*in this picture

*A step ahead-*

# HESLAR RADIO

**T**HE Heslar Radio Corporation, although new in organization, is old in experience. Headed by former Lieut. O. F. Heslar, U. S. N., who has had fourteen years of Radio experience with the government and has made many important improvements in Radio apparatus, this large organization is manufacturing Radio sets and equipment that will simplify the Radio art.



The Sign  
of Superiority  
*Know this sign  
as your guide to  
dependable Radio  
equipment*

Into every Heslar product goes the highest standard of material, the finest craftsmanship and every HESLAR product features important improvements, that have immediately placed HESLAR equipment in great demand. We are already producing jacks, variable condensers, sockets and phones, that show marked advance over the present models. Ask for literature on these improved HESLAR creations.

## Radio Equipment with Last Minute Improvements

Dealers—awake to the wonderful opportunities in radio and who realize the demand for superior quality and advanced apparatus will be quick to get in touch with this large organization.

*Write for Territory at Once—NOW*

**"Heslar Radio-makes the World Your Neighbor"**

# HESLAR

RADIO CORPORATION  
INDIANAPOLIS

Dept. A.

U. S. A

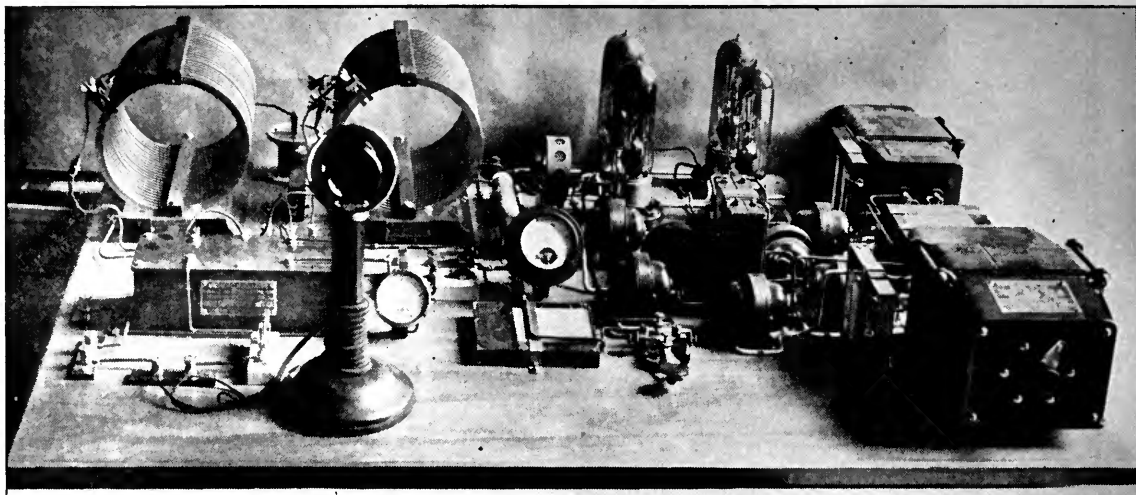

This is a highly refined vacuum tube transmitter circuit, such as is used for instructional and experimental purposes in colleges and laboratories. Completely wired, as this set is, it would be a valuable asset for any dealer, helping him to sell units

stock, which could be substituted for them. For instance, a dealer may handle four or five different types of telegraph keys or microphones, but only one of them appears in the assembly. Unless his list of parts includes the various types he has for sale, he is failing to take advantage of a good opportunity.

A short time ago, the following incident was brought to the attention of a salesman traveling through the South for a large corporation.

In one of the Southern States a man who ran a very flourishing electrical supply business, saw that radio was expanding very rapidly and decided to carry a line of radio equipment. He made rather extensive purchases which included not only small parts but complete transmitting and receiving outfits.

After the stock had remained on his shelves for some little while without showing any tendency to move, this dealer decided that it was a liability and took the necessary steps, as he thought, to wash his hands of it. He made one cut after another in the retail price, but his stock still remained.

In the meantime a competitor loomed up on the horizon in the form of an electrical dealer whose business was rather small and located almost directly across the street. This small dealer merely put in a few radio parts, but spent his evenings at a local radio school and attended the meetings of the local radio club religiously.

It was not long before he was able to talk

radio from the amateur's own viewpoint because he had become an enthusiastic amateur himself.

From his contact with the radio amateurs this man was able so to direct his purchases that a very limited investment followed by a rapid turn-over resulted in a rapid building up of a business which to-day is very substantial.

This story was told to the traveling salesman after he had observed an incident which must have been duplicated many times before by these two stores. A customer came into the store of the first dealer we have mentioned, desiring to purchase a certain unit which carried not only a designating name but a trade name. This particular unit is referred to by the experienced amateur by its trade name alone. The dealer advised this prospective customer that his stock of this class of equipment was exhausted, but he failed to take into account that a similar device made by a different manufacturer was to be found in rather large quantities upon his shelves. It happened that the salesman was in the store at the time and the incident interested him so much that he followed this customer to the competing store across the street. Here the same request was made and here, this dealer too, was compelled to advise this prospective customer that his stock of this type of unit was exhausted. However he did not fail to mention that he had another type which would serve the purpose just as well, if not better. Naturally the sale was made and the customer was





## Rain Won't Injure Your Formica Panels

**F**ORMICA does not absorb moisture so its insulating quality is never affected by weather or even by soaking in water. It does not swell or shrink and never warps. The handsome high gloss finish does not deteriorate. It looks good for years—and is good!

Formica has been approved as Radio Insulation by the navy and the signal corps. It is by far the most widely used Radio insulating material.

Formica is easy to machine and helps you do a workmanlike job on your panel. You can buy it cut to size for a standard Radio panel. All you need to do the work is a drill.

*Dealers:* We supply you with display cards for your store and Formica printed matter. We cut panels to size for you if you wish—and cooperate in every way possible. Extension to our plant will double capacity after July 1st.

### The Formica Insulation Company

4628 Spring Grove Avenue,

Cincinnati, Ohio

#### *Sales Offices*

50 Church Street, New York, N. Y.

9 South Clinton Street, Chicago, Ill.

414 Finance Building, Cleveland, Ohio

1042 Granite Building, Rochester, N. Y.

422 First Ave., Pittsburgh, Pa.

Sheldon Building, San Francisco, Cal.

932 Real Estate Trust Bldg., Philadelphia, Pa.

321 Title Building, Baltimore, Md.

415 Ohio Bldg., Toledo, Ohio

---

# FORMICA

Made from Anhydrous Redmanol Resins

## SHEETS      TUBES      RODS

---

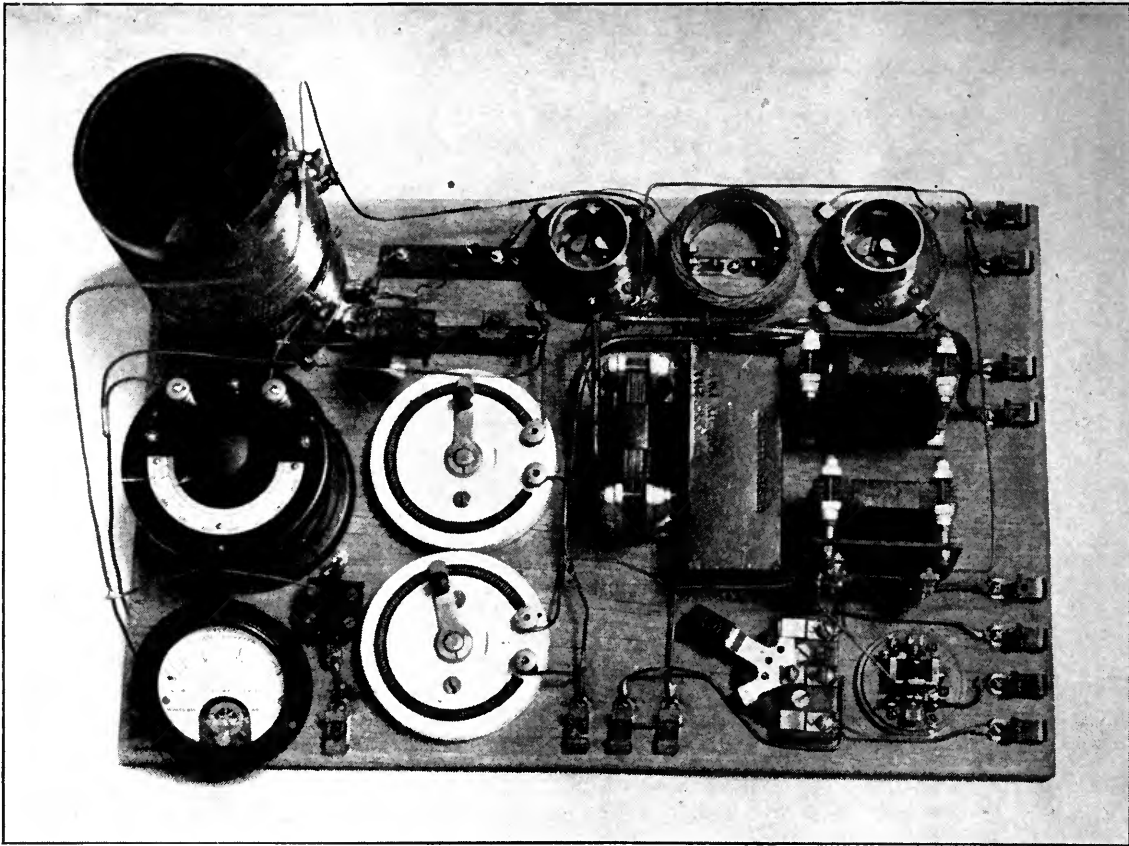

A DISPLAY OF STANDARD RADIO PARTS

Assembled, wired and displayed by a progressive radio dealer—a great help to the buying public

entirely satisfied. Had the proprietor of the first store been sufficiently versed in radio to merchandise his stock properly, it would have been possible for him not only to make this particular sale but, in all likelihood, to secure for himself a steady customer, not only for his radio department, but for every other class of electrical goods he had for sale—and he had just about every kind.

The importance of highly trained personnel cannot be overestimated if the radio department of a general store or the strictly radio store itself is to survive. To-day, to-morrow, and next week, perhaps, the public will make

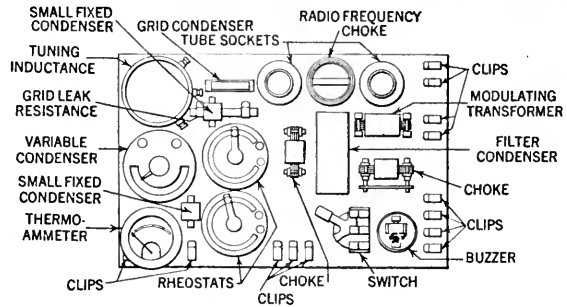

its purchases as best it can, but when the supply begins to equal the demand, it will again become necessary for us to "sell," which is going to be very difficult if the public to whom we seek to make sales has been abused by us.



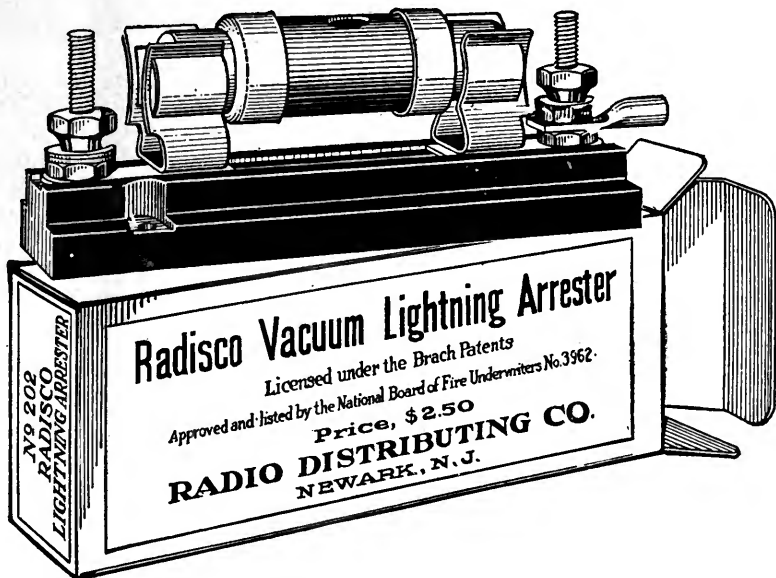

# RADISCO PROTEC-TON

*Automatic Lightning Arrester*

## DEFIES LIGHTNING

**P**ROTECT your home and radio instruments from lightning with a Radisco PROTEC-TON. This "lightning defier" is approved by the National Board of Underwriters, Electrical, 3962. It eliminates the necessity of a lightning switch. It provides the assurance of absolute protection. Make your home safe. Get a PROTEC-TON at once. Price \$2.50.

This is only one of a line of "Radisco Recommended" Specialties carried by your dealer. Go to him and examine them at your leisure, he can make immediate delivery.

*Look for the dealer who displays this sign*

# RADISCO

*"Your Assurance of Satisfactory Performance"*



Authentic information about how to install a Radisco PROTEC-TON to conform with Underwriters' requirements cheerfully given by RADISCO dealers. Go to the nearest RADISCO dealer and let him explain the necessity for this protection.

# The Grid

## QUESTIONS AND ANSWERS

The Grid is a Question and Answer Department maintained especially for the radio amateurs. Full answers will be given wherever possible. In answering questions, those of a like nature will be grouped together and answered by one article. Every effort will be made to keep the answers simple and direct, yet fully self-explanatory. Questions should be addressed to Editor, "The Grid," Radio Broadcast, Garden City, N. Y. The letter containing the questions should have the full name and address of the writer and also his station call letter, if he has one. Names, however, will not be published. The questions and answers appearing in this issue are chosen from among many asked the editor in other capacities.

*What is an electron?*

*Why do hot metals throw off electrons?*

*Why will a current pass through a tube only when the filament is lighted?*

*How many electrons pass from the filament to plate in a detector tube?*

*Can an electron be seen with a magnifying glass?*

*Where do electrons come from?*

### Electrons

EVERY one is more or less familiar with the fact that ordinary matter can be broken up into very small particles. Sugar, for instance, is most commonly seen in the granulated form, which parts are visible to the naked eye. Powdered sugar is another familiar form. It takes a very keen eye to detect the particles of sugar in this form. Sugar may still further be divided by dissolving it in water, say a teaspoonful of sugar to a glass of water. No trace of the dissolved sugar can be seen. Its presence can be detected by tasting the water which is sweet. In dissolving the sugar, it has been broken up into the smallest possible particles. No matter what method is employed, the sugar could not be divided further. Similarly, other materials can be divided and subdivided until there comes a time when no further division is possible. These smallest particles of matter are known as molecules and atoms. An atom is the smallest division of matter. An electron is to electricity what an atom is to matter. An electron, therefore, is the smallest part into which electricity may be divided. It is negative electricity.

It has been shown beyond any possibility of doubt that electrons are present in all kinds of matter—in everything; metals, paper, wood, everything. In the usual state of matter, these electrons do not manifest themselves. But if a body has more than the usual number of electrons or less than the usual number, the body is said to be electrically charged; being charged negatively in the first case, and positively in the second case. As an electron is the smallest possible charge of negative electricity, a body is caused to have a negative charge by an excess of electrons and is caused to have a positive charge by a deficiency of electrons.

From theoretical consideration, it was long suspected that such a thing as the electron existed. Their presence was detected by the use of tubes similar to X-ray tubes. Having detected them, scientists were quick to go about making measurements of them. After a lapse of some time, and as a result of very careful and brilliant work, the mass, electrical charge, and dimension of an electron became known.

One very noteworthy experiment in measuring an elec-

tron was performed by an American, Prof. Millikan of Chicago. He introduced a minute drop of oil of about 1-10,000th inch in diameter in a chamber between two plates whose electrical charge was subject to control. The drop of oil was strongly illuminated and was viewed by a telescope. By controlling the potentials of the plates the oil drop could be made to fall or rise at will. The drop continually picked up and lost electrons. As it picked up an electron, it would move toward the positive plate (unlike charges attract); if it picked up two electrons it would move faster toward that plate. By carefully observing the action of the drop of oil, Millikan was able to determine very accurately the charge added to it by its picking up one electron.

The electron is inconceivably small in mass, in size, and in the charge it carries. It would take more than a million million of them laid side by side to make an inch. Thus it is seen that it is too small ever to be made visible by any means. When an ampere of current is passing through a wire, more than six million million million electrons pass any given point in the wire each second. A detector tube has a plate current of about 20 milliamperes. As this is 1-50th of an ampere, then the number of electrons passing from the filament to plate is about one hundred and twenty thousand million million per second. This number is inconceivably large. Millikan says that the number of electrons which pass every second through a common 16-candle power lamp is so large that it would take two and a half million people, twenty thousand years of twenty-four hour working days to count the number if they all counted at the rate of 120 per minute.

It is seen from the above that a current of electricity is a flow of electrons. When man first commenced to study electricity he thought that there were two kinds, which he named positive and negative. As has been already noted this was an error, for there is only one kind and an excess or deficiency of this kind gives what was called negative and positive electricity. Soon man discovered that if a positively charged body and a negatively charged body were connected by a wire, electricity would flow along the wire. The direction of the flow of current was taken to be from positive to negative. This was also an error which has persisted to the present day. It is now known that nothing passes from the positive to the negative charge. On the contrary, the electrons pass from negative to positive and thus make the current. Ordinarily, however, we speak of the current as passing from positive to negative. The error is so deeply planted in all literature dealing with electricity and so many rules have been formulated upon it that it is too late to change it now. However, when one thinks about electrons, he must be aware of the fact

# UNIVERSAL RADIO CABINET

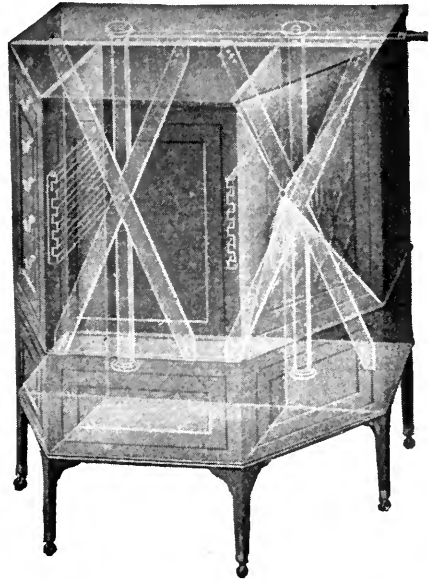

## A Beautiful Piece of Furniture

You can put **your own** receiving set and batteries in this cabinet.

The horn is built in and is a part of the cabinet. The supports for a loop aerial and headphones are supplied, and adjustable shelves will accommodate every piece of apparatus.

Whatever the size of your instruments, they will fit these cabinets and you can install them yourself easily. We will gladly send you a descriptive circular telling how this is done.

Every owner of a radiophone wants one—it is just what you are looking for.

The apparatus will no longer prove a dust-collecting nuisance, scattered about the room—an unsightly obstacle wherever it is placed.

### PRICES PREPAID

Size No. 1—To accommodate single units not exceeding 16" x 13" x 8"	Size No. 2—To accommodate units not exceeding in size 24" x 20" x 10"
Style A \$80.00 f. o. b. Grand Rapids	\$ 95.00 f. o. b. Grand Rapids
Style B 120.00 " " "	145.00 " " "
Style C 160.00 " " "	190.00 " " "

*Ask your dealer for a Universal Radio Cabinet—or send your order direct to*

**FRANK LANE COMPANY**

**Woolworth Building, New York City**

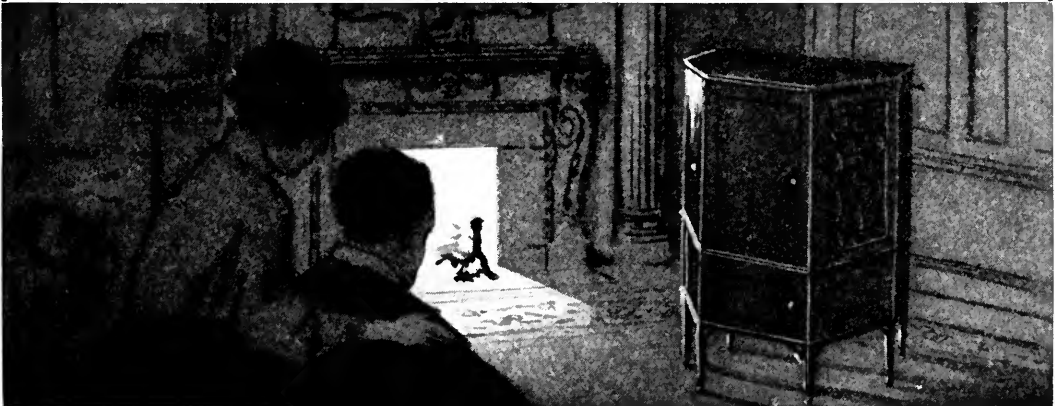

that they flow in the opposite direction from the direction of the current as it is commonly known. In the vacuum tube, for instance, the current is said to pass from the plate to the filament. In reality it is the electrons that pass from the filament to the plate.

As has been stated all matter contains electrons. These electrons are associated with the atoms of the matter. In some atoms the electrons are bound very firmly to the atom and cannot escape. In atoms of other materials, the electrons are held only loosely to the atom and very readily escape. Materials having electrons loosely bound to the atom are conductors of electricity. That is, if they are subject to an electromotive force (voltage) the electrons will move. One must not think that the same electrons pass all the way through the wire. The electrons are fed in at one end and other electrons escape at the other end. Thus in a battery with a completed circuit, it will take a long time for any particular electron to go completely around the circuit. But as soon as one electron leaves the battery another electron enters it.

The temperature of a body is caused by the motion of the atoms composing that body. If the motion of the atoms ceased, the body would have a temperature of absolute zero—that is, 461 degrees Fahrenheit below zero. As the rapidity of the motion of atoms increases, the temperature of the body increases, so that at very high temperature the motion of the atom is very rapid. The electrons are a part of the atom and hence share in its motion. In fact their velocity is much greater than the atom.

Water evaporates. Evaporation of water is caused by molecules of water (a molecule corresponds to an atom)

attaining such a high velocity that they escape from the rest of the water into the air, thus forming water vapor. Heat the water and the rate of evaporation increases. Heat it to the boiling point and the escape of the water molecules occurs not only at the surface of the water, but also within the water. Thus it is seen that an increase of temperature increases the velocity of the water molecules, which means that an increased number of them escape from the water.

At very high temperatures, under special conditions, metals can be made to evaporate. Thus it is possible to give the atoms of metals such a high velocity that some of them will escape from the rest of the metal. In the same way if the temperature is high enough (i. e., the velocity great enough) electrons will escape from a hot body. This evaporation of electrons will take place at a much lower temperature than would be required to evaporate the metal itself.

A hot body then emits electrons. It is this fact that is made use of in the vacuum tube. Heating the filament of a vacuum tube causes it to throw off electrons, which pass to the plate and thus make an electric current. If the filament is not heated, there are no electrons available and hence no current can pass.

In concluding it must be brought to the attention of the reader that some materials emit electrons more readily than others. The condition of the surface of a metal has an important effect upon the number of electrons emitted. Thus it happens that some vacuum tubes must have their filaments white hot, and other tubes must have their filaments only red hot for good results.

## New Equipment

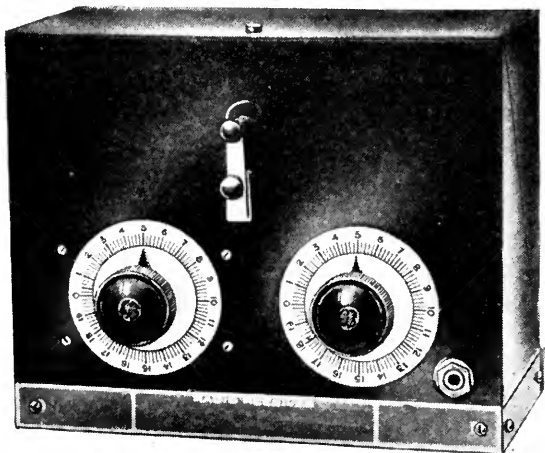

Exterior new General Electric short wave tuner embodying many new features. This tuner may be used with a crystal detector or vacuum tubes. An important feature is the metal case, used instead of the usual wood cabinet. This metal furnishes an effective "shield," preventing capacity effects between the receiver itself and the body of the operator

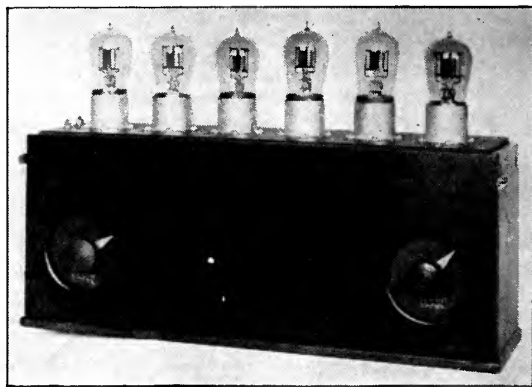

Exterior view of a new amplifying unit made by the Wireless Specialty Company for its use in conjunction with loop aerials and loud speaker. Six vacuum tubes are employed, but they function as eight, because two of the tubes are used twice. The complete unit operates as five stages of radio frequency, detector, and two stages of audio frequency. This unit has been built more for demonstration purposes than for general use.



# Now Ready!

## THE MARSHALL VARIABLE CONDENSER

designed by expert radio engineers of long standing and made of best materials throughout.

Front and back plates of selected hard rubber. Central mandrel turns in brass bushing and is adjusted through one or more cone bearings. Plates and separators, of especially prepared aluminum, cannot get out of true.

### ASSEMBLED CONDENSERS

3 Plates, capacity .00014, \$2.50	9 Plates, capacity .00033, \$3.50	35 Plates, capacity .00121, \$ 6.00
5 " " .00021, 2.75	17 " " .00061, 4.25	67 " " .0023, 12.00

## —Here's A New Idea Build Your Own Condenser

**SAVE** money. No technical experience necessary. Lots of fun! You may now buy the Marshall Condenser in all standard capacities knocked down ready for assembling at prices materially lower. Complete instructions for assembling furnished with each outfit.

### READY TO BUILD

3 Plates	capacity .00014	\$1.90
5 " "	" .00021	2.10
9 " "	" .00033	2.55
17 " "	" .00061	3.35
35 " "	" .00121	5.15
67 " "	" .0023	9.40

Prices on other units on application, including non standard units to suit capacities needed to unify various non standard antennae and receiving outfit units.

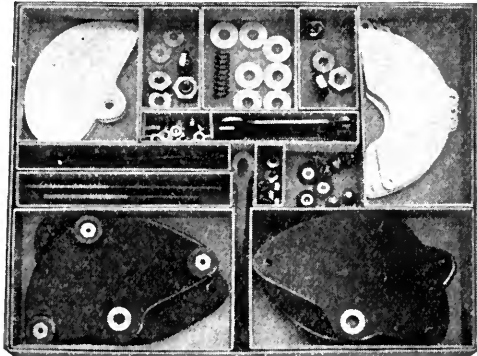

*Special Outfit Containing 2 Marshall Variable Condensers Ready for Assembling*

*Marshall Condensers are very ruggedly built for C.W. work either sending or receiving*

**Note:**—If your dealer cannot supply you, write us direct enclosing remittance, together with dealer's name and address and the Marshall Condenser will be sent you anywhere in the United States parcels post paid. Order at once.

**Live Wire Retailers**—Our new selling plan will interest you. Write. We do not want cash from responsible parties. To such our terms are 30 days net, or we will ship C. O. D. when no credit or references are given. Discounts better than usual.

**Radio Salesmen**—Perhaps we have no representative in your locality. If you are a hustler let us hear from you. Several good men needed as district managers.

## NEW HAVEN RADIO COMPANY

MANUFACTURERS

61 Hamilton St.,

New Haven, Conn.

## New Equipment



This is a very popular receiving set, covering a wave length range of 150 to 1,000 meters. The set itself is entirely mounted on a single Bakelite supporting panel and is encased by an attractively finished oak box having a hinged cover

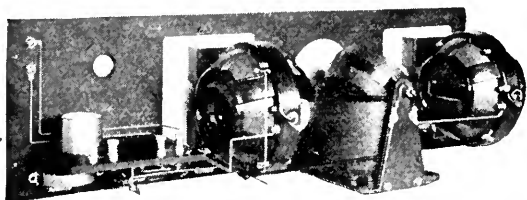

This is the interior of the 150 to 1,000 meter receiver, and, as may be seen, the vario coupler and variometers are of new design and are entirely shielded to prevent body capacity effects

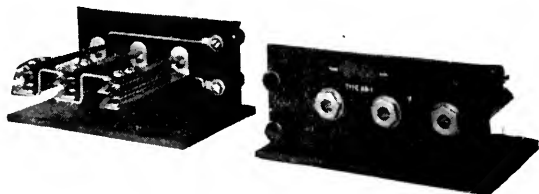

This automatic triple jack is used where several pairs of telephone receivers are employed with a single receiving set. The telephone plugs may be inserted in the jacks at will and the proper arrangement of connections is automatically made

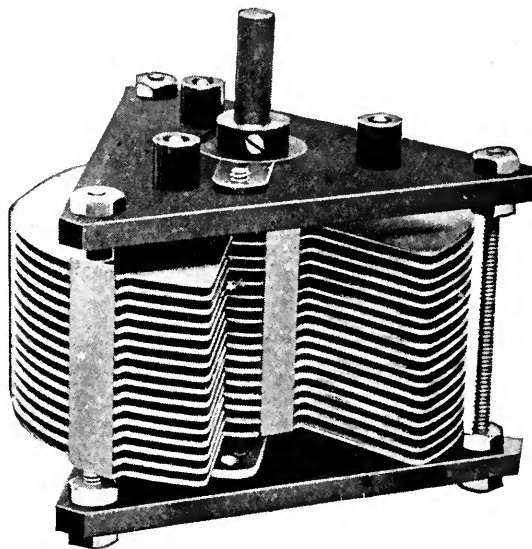

New variable air condenser of the General Radio Company, Cambridge, Mass.

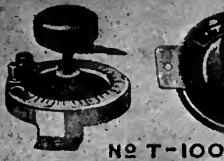

No. T-100



No. T-101



No. T-106

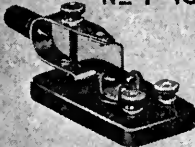

No. T-105



No. T-102



No. T-103  
No. T-104



N-S  
NAA  
CRYSTALS



N-S  
"RED-HEAD" PHONES



**Introducing Seven *Better* Radio Instruments**

15 years of direct contact with the radio field has enabled us to develop these products. Each has new and unusual features that place it far ahead of common types—not one is a rushed-on-the-market experiment.

**HERE THEY ARE**

**No. T-100 Reversible Rheostat**—all metal type for table or panel mounting. For use with any detector or amplifier bulb—smooth action, perfect contact, substantial pointer with insulated knob.  
—a *better* rheostat  
**Price \$1.00**

**No. T-101 V. T. Socket**—Mechanical features that make it the only socket on the market that is genuinely rigid and strong when used for panel mounting and yet perfectly adapted to table or base mounting. All metal with Bakelite contact support.  
—a *better* socket  
**Price 75c**

**No. T-106 Adaptaphone**—Converts the sound chamber of phonograph into a loud speaker. Made of high-grade rubber. Will not scratch or mar parts of phonograph. Not necessary to remove cap from receiver. Will fit all phonographs except the Brunswick.  
—a *better* adapter  
**Price \$1.00**

**No. T-105 Crystal Detector**—New and ingenious design provides every adjustment to facilitate proper contact with the crystal. Contact wire can be moved to any point on crystal. Pressure can be easily regulated. Contact wire instantly renewable.  
—a *better* crystal detector  
**Price \$1.00**

**No. T-102 Stopping Condenser**—Heavy metal plates of novel design form substantial case for

condenser. Mica dielectric, capacity .0005 MF. Highly nickle-plated and polished, mounted on insulating base. Can be removed for panel mounting.  
—a *better* stopping condenser  
**Price 75c**

**No. T-103 Grid Condenser**, of similar design as above. Proper capacity for grid circuit in V. T. Hookups.  
—a *better* grid condenser  
**Price 40c**

**No. T-104 Moisture-Proof Variable Grid Leak**—arranged for front of panel mounting in connection with Grid Condenser. Nickle-plated and polished cover.  
—a *better* grid leak  
**Price 60c**

—and *better than ever the famous*

**N-S "Red-Head" Phones**—3000 ohms. A triumph in Radio Receiver design. Beauty of design and ruggedness of construction coupled with a supreme sensitivity are features that make "Red-Heads" the ideal telephone receivers for radio work.  
**Price with Cords \$8.00**  
—and

**N-S NAA [Arlington Tested] Supersensitive Crystals**, individually tested and packed in convenient metal boxes. Galena, Silicon or Goldite, price each 25c. Same mounted in cup, 40c each.

Number yourself among our thousands of friends and customers who know the reliability and accuracy of N-S Radio Products.

*Send for Bulletin A which describes these products in detail*

**Dealers: Write for our very attractive proposition. IMMEDIATE DELIVERY**

**The Newman-Stern®**  
**Teagle Radio Division**  
**CLEVELAND-OHIO**

## New Equipment

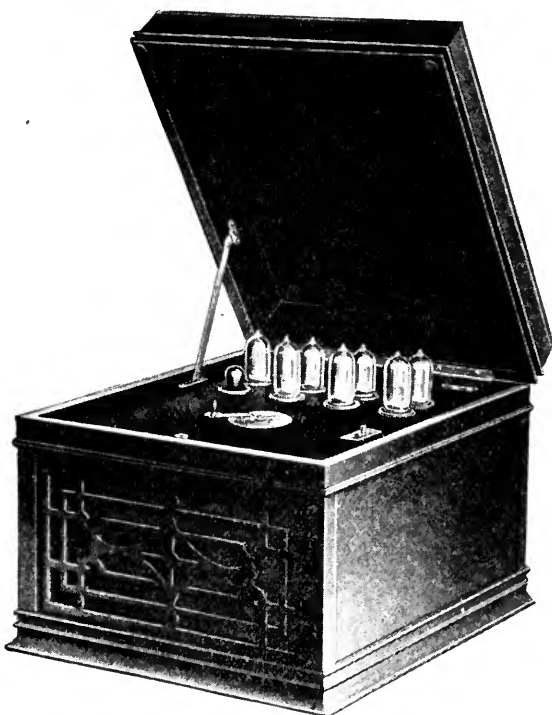

Aeriola Grand showing the vacuum tubes and ballast tubes in place, the switch which controls the entire current supply, and the single control lever used to tune in desired and tune out undesired broadcasting stations

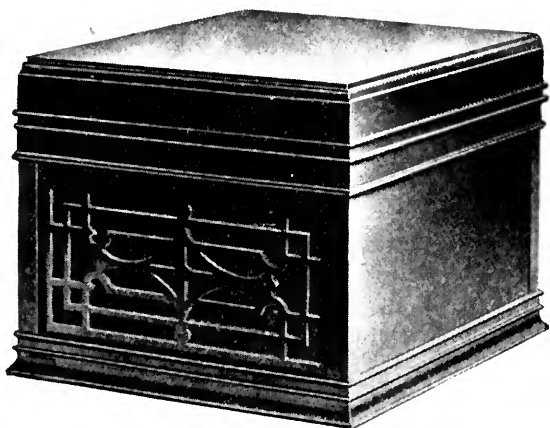

Aeriola Grand. The latest development of the Westinghouse Electric and Manufacturing Company is a complete broadcasting receiver equipped with a series of vacuum tubes, the necessary plate batteries, and a loud speaker, all mounted within the mahogany cabinet shown here. The operation of this set is so simple that it may be readily performed by a very young child



Westinghouse Vocarola. This is a complete loud speaker equipped with an especially designed reproducer having a corrugated metal diaphragm designed to produce music and speech without distortion. As may be seen, a telephone plug is provided for connecting the loud speaker to the receiving set

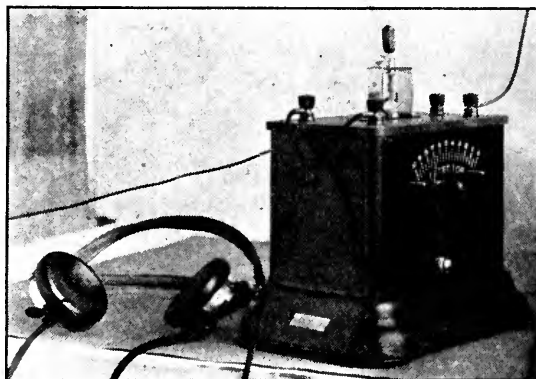

A new compact receiving set, the Federal, Jr., of the Federal Telephone & Telegraph Company

*Give Your Radio Set the Advantage of*

# WESTINGHOUSE RADIO BATTERIES



Westinghouse "A" Batteries are especially built for the peculiar requirements of radio work. They deliver a constant, dependable flow of low voltage current. They are built to give long, low-cost service. They demand a minimum of attention.

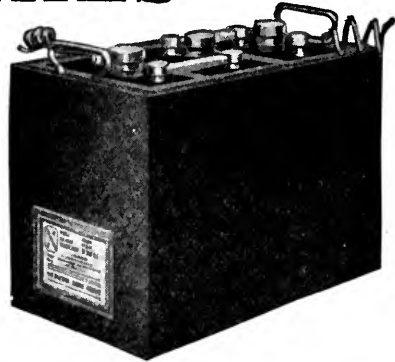

In the Westinghouse "B" battery you have a *storage* battery for "B" work—the latest development in radio practice. It has all the reliability and dependable performance of a storage battery and none of the disadvantages of a dry cell. The Westinghouse "B" gives a steady, continuous, noiseless service. It lasts indefinitely. When exhausted it is easily recharged. The first cost is the last cost.

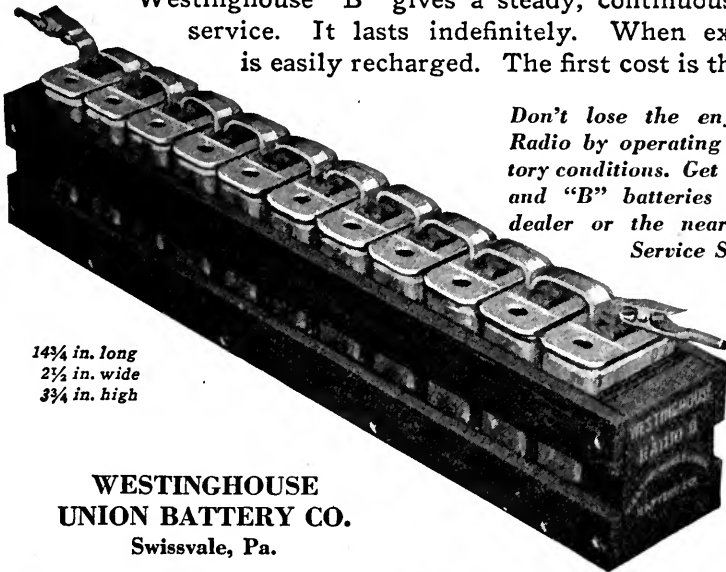

14¾ in. long  
2½ in. wide  
3¾ in. high

**WESTINGHOUSE  
UNION BATTERY CO.**  
Swissvale, Pa.

*Don't lose the enjoyment of your Radio by operating under unsatisfactory conditions. Get Westinghouse "A" and "B" batteries from your radio dealer or the nearest Westinghouse Service Station.*

*"The best  
Westinghouse  
can build."*

## New Equipment

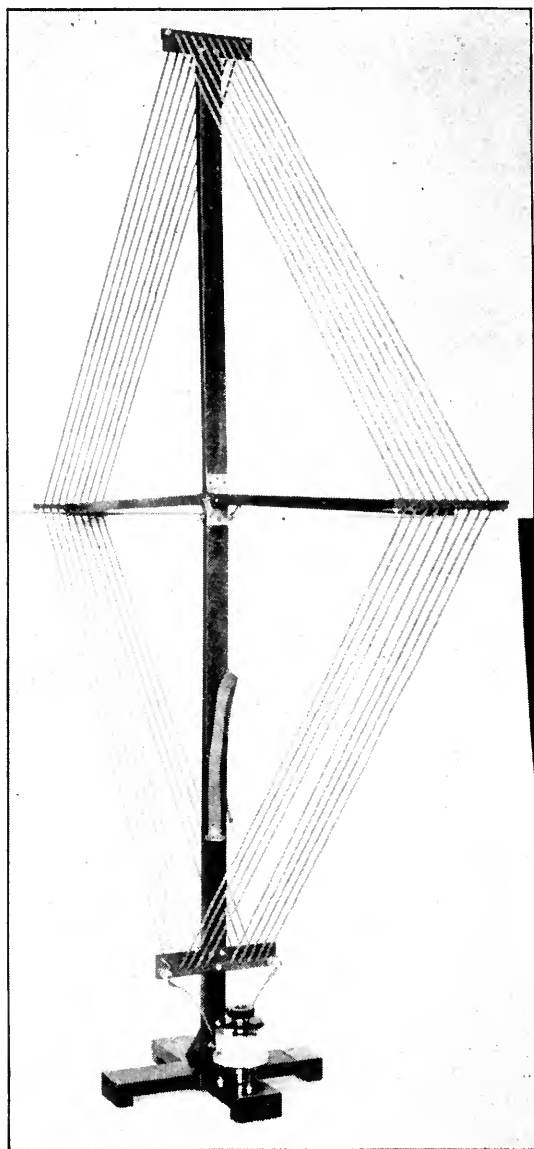

Collapsible loop antenna designed especially for broadcasting reception. This loop is made by the Wireless Specialty Company and the frame is of artistically finished mahogany, suitable for use in any living room. This loop has been designed for use in conjunction with several stages of radio and audio frequency amplification.

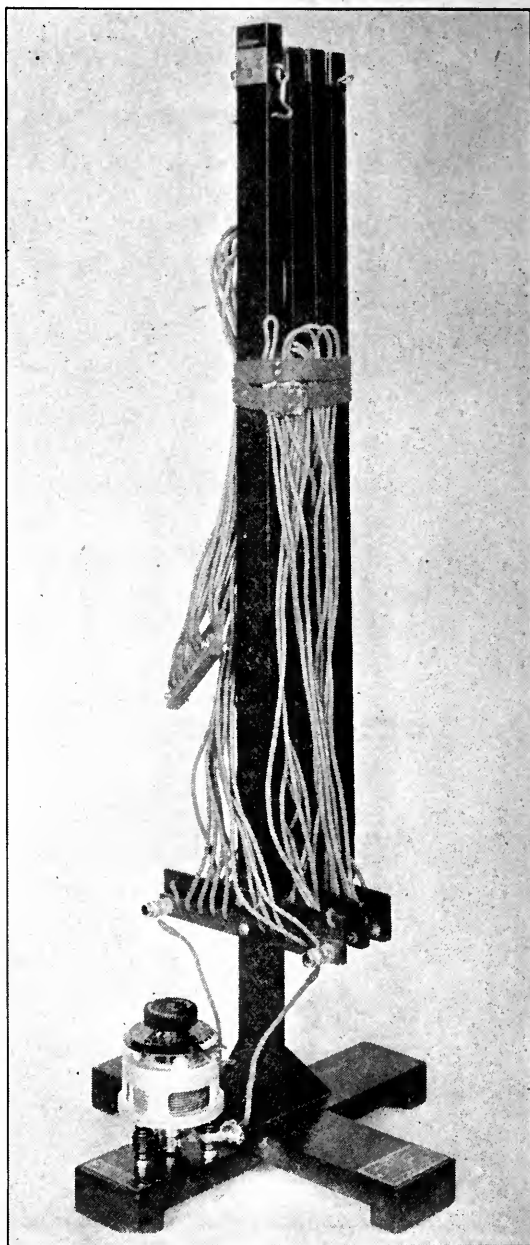

This is the same loop collapsed, showing its small size, making it readily portable. As may be seen, the wires are held in place by specially constructed bakelite frames. The variable condenser mounted on the leg of the stand is of entirely new design and is diecast throughout. This condenser is also manufactured by the Wireless Specialty Company.

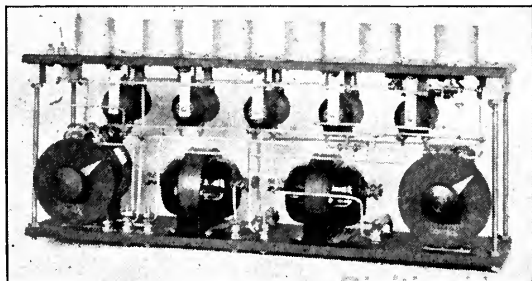

This is the interior of the six tube amplifier shown on p. 180, and, as may be seen, the filaments of all six tubes are controlled by two switch arms. The workmanship in this unit is particularly striking, and, from an operating standpoint, the fact that six tubes function as eight, indicates that we may expect a great reduction in the cost of operation. Exceptional results have been secured with this unit and a loop antenna



Use Kennedy Receivers for Effective Reception  
*You can't go wrong—Quality always counts*

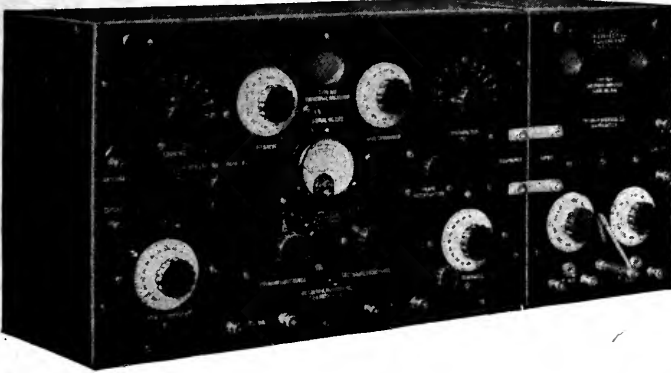

**KENNEDY**  
**EQUIPMENT**      Look  
 for the  
 Trade  
 Mark

TYPE 110 UNIVERSAL  
 REGENERATIVE RE-  
 CEIVER, WITH TYPE  
 525 TWO STAGE AMP-  
 LIFIER. WRITE FOR  
 BULLETINS.

*All Kennedy Regenerat-  
 ive Receivers are licensed  
 under Armstrong U. S.  
 Patent No. 1,113,149.*

**A** UNIVERSAL RADIO RECEIVER, in fact, as well as in name, the Kennedy Receiver Type 110 can be made to detect, regenerate or oscillate at will, over its entire range of 175 to 25,000 meters. Cabinet is of solid walnut, hand rubbed finish—Kennedy Quality and Workmanship evident throughout.

Like the Universal Receiver, Type 525, two-stage amplifier is built for dependable service. It matches the receiver in height, depth and general finish.

**THE COLIN B. KENNEDY COMPANY**  
 INCORPORATED

RIALTO BUILDING

SAN FRANCISCO

**HOME-O-FONE**

**Radio Telephone Receiving Set**

**\$24**  
**COMPLETE**  
*including Antenna, etc.*  
*No batteries or tubes needed*  
 Every Set **GUARANTEED**



**L**ISTEN IN with a sturdy, practical radio set that you can be proud of—not a toy or a makeshift. You will not know what a crystal set can do unless you get a Home-O-Fone, the quality package outfit. You are sure of satisfying results with a HOME-O-FONE because it is scientifically correct. But in addition, this De Luxe Package set is constructed of only the highest grade materials and designed to retain its handsome finish as well as its efficiency. An addition to the appearance of any room. Tuned with one simple adjustment—no extra parts required. Guaranteed to hear the broadcasts in your own or nearby city.

**Complete Outfit Includes:—**

HOME-O-FONE No. 2 RECEIVER with prevision tune adjustment, in handsome cabinet-finish case with cover and compartment for headset, etc.—**DOUBLE HEADSET**, with two special "RR" concert 'phones, 2200 ohms, headband and long telephone cord—**ANTENNA WIRE**—150 feet.—**GROUND CLAMP**.—**HIGH INSULATION RADIO RECEIVER**—**CABLE** for room connection—25 feet. **SPECIAL PORCELAIN INSULATORS** for antenna—4.—"ANCHOR" **AUTOMATIC RADIO LIGHTNING PROTECTOR** as required by National Underwriters' Rules.—**INSTRUCTION FOLDER**.

**IMMEDIATE DELIVERIES**

*Send for folder containing Antenna drawing. A few select territories still open for live dealers.*

**RADIO RECEPTOR COMPANY, INC.**  
 No. 1 Madison Avenue      New York, N.Y.

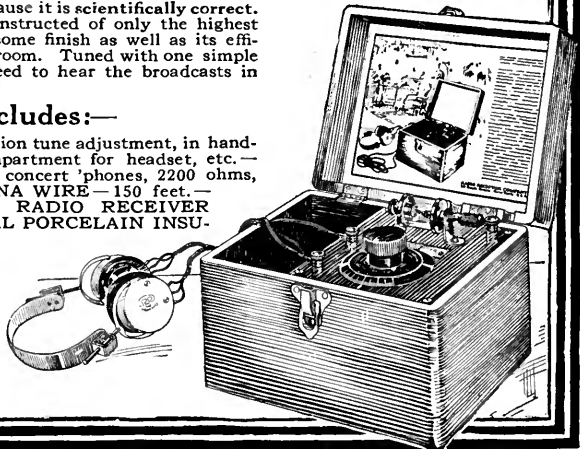

# What to Call Them

THE recommendations of the Committee on Nomenclature of the Radio Telephone Conference called by Secretary Hoover of the Department of Commerce in Washington were as follows:

1. In place of the word "Wireless" and names derived from it, use the prefix "Radio"; Radio Telegraphy, Radio Telephony.

2. Instead of "Statics" or "X's," use "Atmospheric Disturbances" or "Atmospherics."

3. Disturbances produced by other stations to be designated as "Interference."

4. For the title of a triode employed in one of its regular modes, use "Rectifier triode," "Amplifier triode," "Generator triode."

5. In describing coupling of high frequency circuits, use "Resistance Coupling," "Inductive Coupling" (by self-inductance or mutual inductance), "Capacity Coupling."

6. For the generic title for a system of conductors for radiating or absorbing radio waves, use "Aerial."

For an open circuit aerial use "Antenna."

For a closed circuit aerial use "Coil."

7. For a receiving arrangement in which beats are produced by a separate local oscillator, use "Heterodyne."

For a receiving arrangement in which the same electron tube is used for generating oscillations and detecting, use "Self-heterodyne."

8. Classification of waves emitted by radio transmitters.

Type A—Continuous Waves.

Waves that in the permanent state are periodic and such that their successive amplitudes of oscillations are identical.

Type A<sub>1</sub>—Manipulated Continuous Waves.

Continuous waves of which the amplitude or frequency vary under the action of hand telegraphic manipulation.

Type A<sub>2</sub>—Continuous Waves with audible frequency modulation.

Continuous waves of which the amplitude or the frequency vary according to a periodic law of audible frequency. This is commonly referred to as ICW method of transmission.

Type A<sub>3</sub>—Continuous waves with speech modulation.

Continuous waves of which the amplitude or the frequency vary in accordance with speech vibrations (radio telephony.)

Type B—Damped Waves:

Waves composed of successive trains in which the amplitude of the oscillations after having reached a maximum decreases gradually. This refers to waves from spark transmitters or other types of transmitters having a characteristic decrement similar to spark transmitters.

NOTE 1. If in continuous wave transmitters the rectified plate voltage is not substantially constant direct voltage, the station should be classed under Type A<sub>2</sub>.

NOTE 2. In ICW transmitting stations if the variation in the wave length or frequency of the transmitted wave is effected in a gradual way (sinusoidally) the station should be classed under Type A<sub>2</sub>. If the variation in frequency or amplitude is abrupt (chopper method) it should be classed in Type B.

In order to differentiate between the amateur and the experimenter, the following definitions are suggested for consideration:

The amateur is one who operates a radio station transmitting, receiving, or both, in a non-professional way, merely for personal interest or in connection with an organization of like interest.

An experimenter is one who operates a transmitting or receiving station, or both, for exclusively technical or scientific investigations.

NOTE. Further recommendations or nomenclature to be added later.

